



TECHNICAL DESCRIPTION

OPERATION AND MAINTENANCE MANUAL

for

Emergency parachute ATL - 88/90 - 1A

(ATL - 15)

number P – 001 – 15

Number of issue: 5

Date of issue: 11.5.2018

Validity from serial number 1846086

LIST OF CHANGES

If the necessity occurs to change or complete the text of this manual, the owner will receive a notification by means of bulletins approved by the Design Organisation or EASA agency which will include new (amended) sheets. The owner of the manual is obliged to record the received changes in the List of changes and replace the invalid sheets for the applicable sheets. The changed or amended parts of the text will be indicated on the side by means of a vertical line and at the bottom with the number and date of the change issue.

Change serial number	Chapter	Number of sheets subject to changes	Date of new sheets' issue	Bulletin number of change issue	Bulletin approval date	Date of completion Signature



TECHNICAL DESCRIPTION

OPERATION AND MAINTENANCE MANUAL

for

Emergency parachute ATL - 88/90 - 1A

(ATL - 15)

number P – 001 – 15

CONTENTS:

	Page
CHAPTER I.	
Technical description of emergency parachute ATL - 88/90 - 1A (ATL-15)	
1. Designation	7
2. Technical parameters	7
3. Parachute function	9
4. The set of parachute	9
5. List of replaceable parts	10
6. Technical description of the parachute	11
CHAPTER II.	
Instructions for the packing of the parachute	
1. General instructions	18
2. Inspection of the parachute before packaging	18
3. Packaging tools	19
4. Parachute package	19
CHAPTER III	
Instructions for using the parachute	
1. Preparation of the parachute before flying	36
2. Parachute opening	36
CHAPTER IV	
Storage and transport of the parachute	
1. Preparation of the parachute for storage	37
2. Storage of parachutes	37
3. Parachute transport	37
CHAPTER V	
Maintenance and repairs of the parachute	
1. Parachute maintenance	38
2. Parachute repair	38

CHAPTER I

Technical description of emergency parachute ATL - 88/90 - 1A (ATL-15)

1. Designation

Emergency parachute ATL – 88/90 – 1A (ATL-15), (hereinafter referred to as the parachute) is designed as **personal parachute assemblies for flight crew equipment and for passengers in emergency situation.**

The parachute complies with standards of European technical standard order ETSO C23d and standard SAE AS8015B.

2. Technical parameters

a) Basic parameters

- Canopy area			36m ²
- Max. parachute mass:			
Part number	09999	5.8 kg	with metal parts H335 + H 337
	09998	6.3 kg	with metal parts H405 + H 323
	09997	6.4 kg	with metal parts H395 + H 323

The parachute mass are defined without the portable bags and back padding.

- dimensions of the packed parachute	length	530 mm
	width	330 mm
	height	80 mm

- force required for pulling out the ripcord	23 ÷ 97 N
--	-----------

b) Design

The parachute is made in three designs.

c) Functional parameters

- average vertical descent speed	
at load G = 122 kg	up to 7.1 m.s ⁻¹
- turning by 360°	8.6 s

d) Limiting of parachute using:

- max. operating weight	122 kg (269 lb)
- max. operating speed (at the moment of the container opening)	278 km.h ⁻¹ (150 kt EAS)
- min. allowable altitude of the use	100 m AGL
at the aircraft speed	110 km.h ⁻¹
- environmental immunity	from - 40 to + 93.7 °C

Note: The parachutes showed the reliable function at the tests with the loaded weight 147 kg (324 lb) - max. operating weight x 1,2 at the speed 333,6 km.h⁻¹ (180 kt EAS) - max. operating speed x 1,2.

e) Warranty term

Warranty period is 5 years providing the repair work and replacement of worn parts is provided in time, storage and transport conditions observed, and regular inspections related to the parachute canopy ventilation are performed. The warranty period is calculated from the parachute dispatch date, however maximum 6 months from the production date (defined on the canopy and the label on the parachute package).

The manufacturer will not accept claims in the cases below:

- If a violent parachute damage occurs or the instructions are not observed as detailed in the Technical description and the operation and maintenance manual:
- If the parachute logbook is not attached to the parachute or if it is incorrectly filled;

If the parachute logbook gets lost a person from the user's staff authorized by the manufacturer carries out a visual inspection of the parachute combined with a record describing the parachute's condition entered in the Inspection report for the parachute that is necessary to issue a copy of the original parachute logbook. Such record shall be sent to the manufacturer for storage and on the basis of a satisfactory result of this record the manufacturer shall issue a new parachute logbook marked as "COPY".

Visual inspection of the parachute can be performed at the manufacturer's site. An entry specifying the parachute's condition is made into the Check sheet.

If the parachute manifests damage the nature of which may lead to the assumption that mechanical and physical properties of materials used have changed (stains of unknown origin, serious burning, shifts of threads in fabric, damaged lines, worn and torn straps or other marks of excessive damage) the organization authorized to perform the maintenance will perform the mechanical-physical testing of the parachute materials.

In case the parachute requires repair work, the organization authorized for performing maintenance will perform it based on agreement with the user.

f) Lifetime

The total parachute lifetime is specified for the maximum of 20 years from the production date providing the instruction specified in the Technical description and the Operation and maintenance manual are observed.

The total lifetime depends on the technical state of the parachute or its parts.

The person authorized to perform the parachute packaging for use, must perform the inspection of the parachute completeness and its technical state prior to its packaging for use.

If the parachute state is compliant, an authorized person will pack the parachute. The parachute eligibility for further operation is confirmed for the period of max. 365 days.

The person authorized can apply this procedure until using the total lifetime of the parachute.

In case of finding unsuitable technical state of individual parachute parts which is in breach of the regulations stated in the Technical description and the Operation and maintenance manual, the parachute must be eliminated from operation, and the incompliant part must be replaced, or the parachute must be sent to an organization authorized for performing maintenance.

The organization authorized for performing maintenance will recommend the performance of potential repair work of the parachute or eliminate the parachute from operation and terminate its use.

- g) The environmental immunity of the parachute is between from - 40 to + 93.7 °C at relative humidity compliant with the temperatures. The parachute can be packed prior to use for the maximum of 365 days.

During each use it is necessary to professionally check the parachute, and if required, send it for repair to the organisation authorized to perform the maintenance.

The inspection conclusions are recorded in the parachute logbook.

3. Parachute function

After leaving the aircraft, the pilot activates the parachute by pulling out the ripcord from the pocket located on the left side of the harness at the chest height. By pulling the ripcord handle from the chest to the waste of the pilot, the ripcord pins will be pulled out from the closing cord lugs, the container flaps will be released, and the pilot chute will shoot in the air flow pulling out the canopy with the lines from the container. The lines will then be released from the rubber bands of the closing flap, spread over the whole length, and the canopy will be filled with air. Completely filled canopy provides calm floating and safe landing.

4. The set of parachute (fig. 1)

The parachute includes the main parts:

I. Pilot chute	PV – 031 – 1A	1 pcs
II. Bridle	SŠ – 054	1 pcs
III. Canopy	V – 070 – 2A	1 pcs
IV. Harness	PS – 041 – 1A	1 pcs
IV. Container	OP – 094 – 1A	1 pcs
V. Ripcord	U – 091	1 pcs
VI. Back padding	P – 032 *	1 pcs
VIII. Back padding	P – 030 *	1 pcs
IX. Portable bag	G – 225	1 pcs

- * The parachute assembly always contains at least one back padding according to the user's request. At the request of the user, it is also possible to deliver the further mentioned back padding.

5. List of replaceable parts

5.1. Pilot chute	PV - 031 - 1A
5.2. Bridle	SŠ - 054
5.3. Ripcord	U - 091
5.4. Portable bag	G - 225
5.5. Closing cord $l = 300_{-10} \text{ mm}$	SU - 001 *
5.6. Rubber band	$2 \times \frac{3}{8}''$
5.7. Rubber band	$1 \frac{1}{4} \times \frac{3}{8}''$
5.8. Back padding	P - 032
5.9. Back padding	P - 030

* The indicated length is measured at a load of 100N.

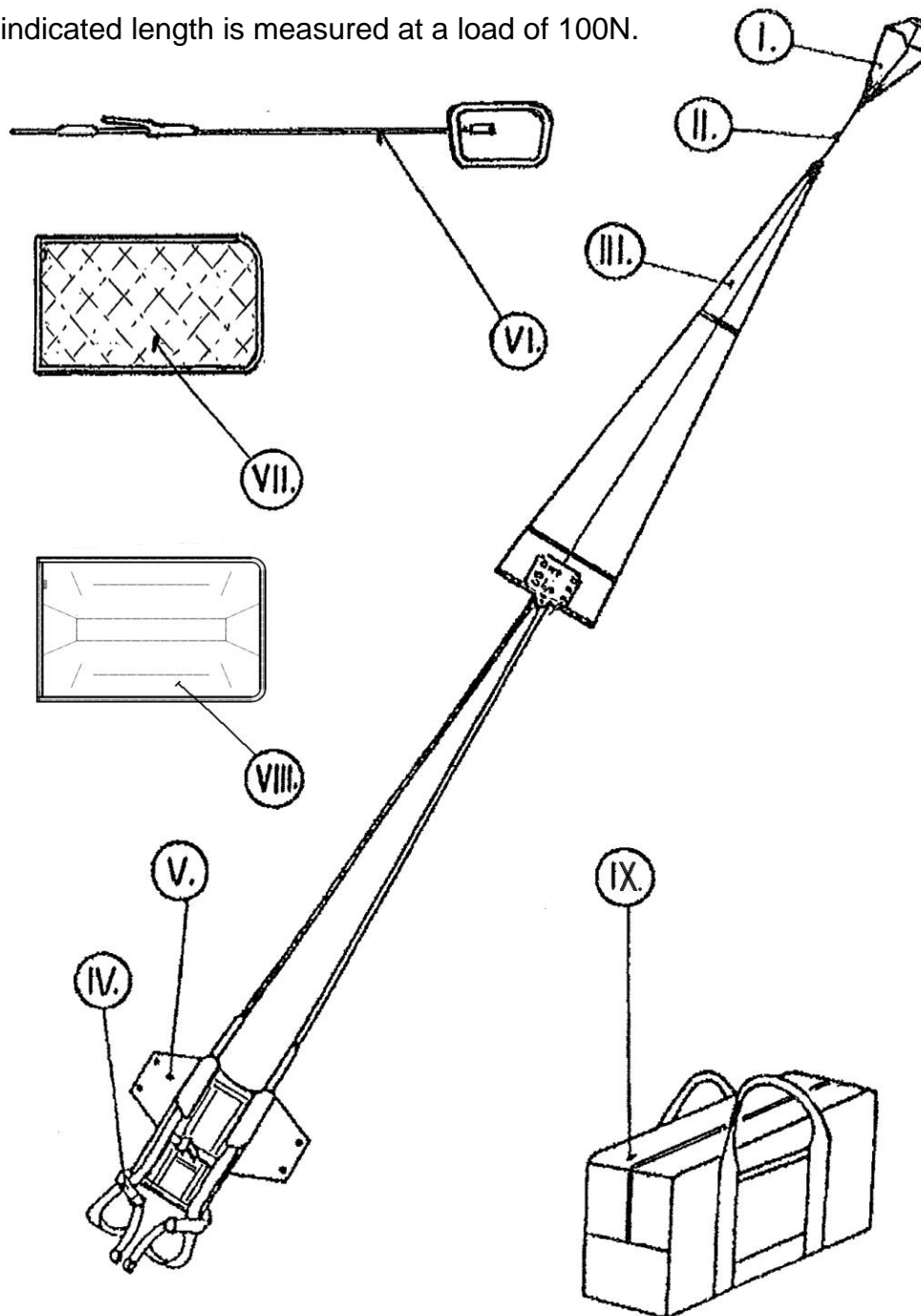

Fig. 1

6. Technical description of the parachute

6.1. Pilot chute PV – 031 – 1A (fig. 2)

It is designed for pulling out the canopy from the container. The base of the canopy (1) of the pilot chute, and it is made of polyamide fabric.

The stop (2) is made of woven curtain – rough. The pilot chute is reinforced with tapes (3), which form the fastener in the lower part (4). Cylindrical shape steel spring (5) is sewn in the pilot chute. The top part of the pilot chute and the location of the spring attachment include the sewn tape loops with fitted metal grommets (6), designed for passing through the closing cord and folding and fitting the pilot chute in the container.

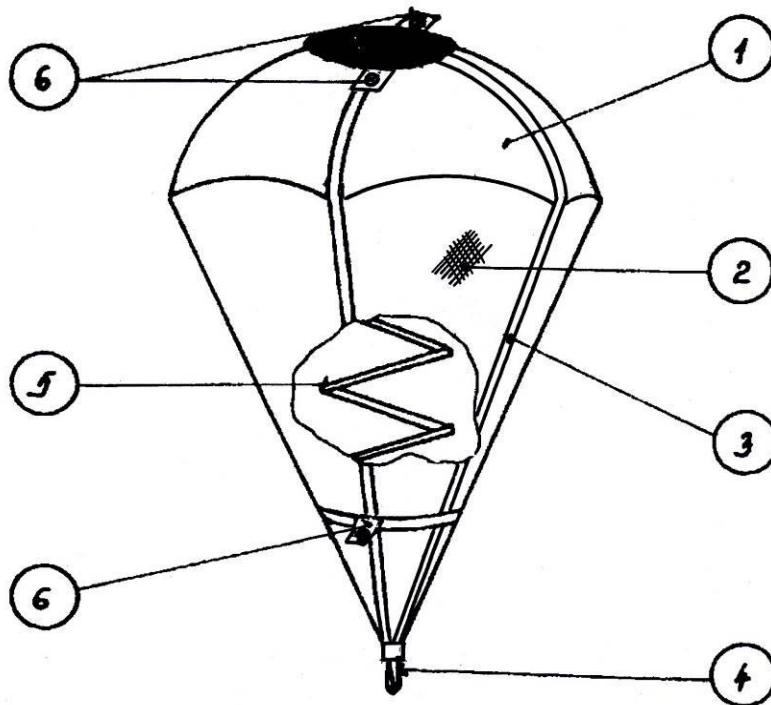

Fig. 2

6.2. Bridle SŠ – 054 (fig. 3)

The bridle connects the pilot chute with the pole vent cords of the parachute canopy. It is made from polyamide cavity with 2,000 mm length. Both ends of the bridle are fitted with lugs for the connection with the canopy and the pilot chute.

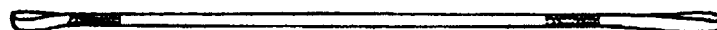

Fig. 3

6.3. Canopy V – 070 – 2 A (fig. 4)

Canopy (1) with surface area 36 comprises of two types of polyamide fabrics and it comprises of 20 fields.

The canopy construction is reinforced with 13 mm tapes – bearing (2) and round (3), (4) and (5).

The lower edge (6) and the pole vent edge (7) are reinforced with 15 mm strap.

The pole vent is reinforced with pole vent cords (8). The rear part of the canopy includes two fields (9) partially filled with curtain woven – fine, which provides the stability, forward speed and control features of the parachute.

The canopy includes 20 attached suspension lines (10) in length 5.000 mm with minimum strength 2.600 N. The lower part includes attached steering lines (11) of red colour to lines No. 3 and 18. The suspension lines during the packaging are placed into the rubber bands $2 \times \frac{3}{8}$ " of the closing flap (12), which is sewn at the lower edge of the canopy at the suspension line No. 11. The suspension lines No. 1 and 20 are fitted with marking (13) for simpler canopy placing at the lower edge and at the risers of the harness.

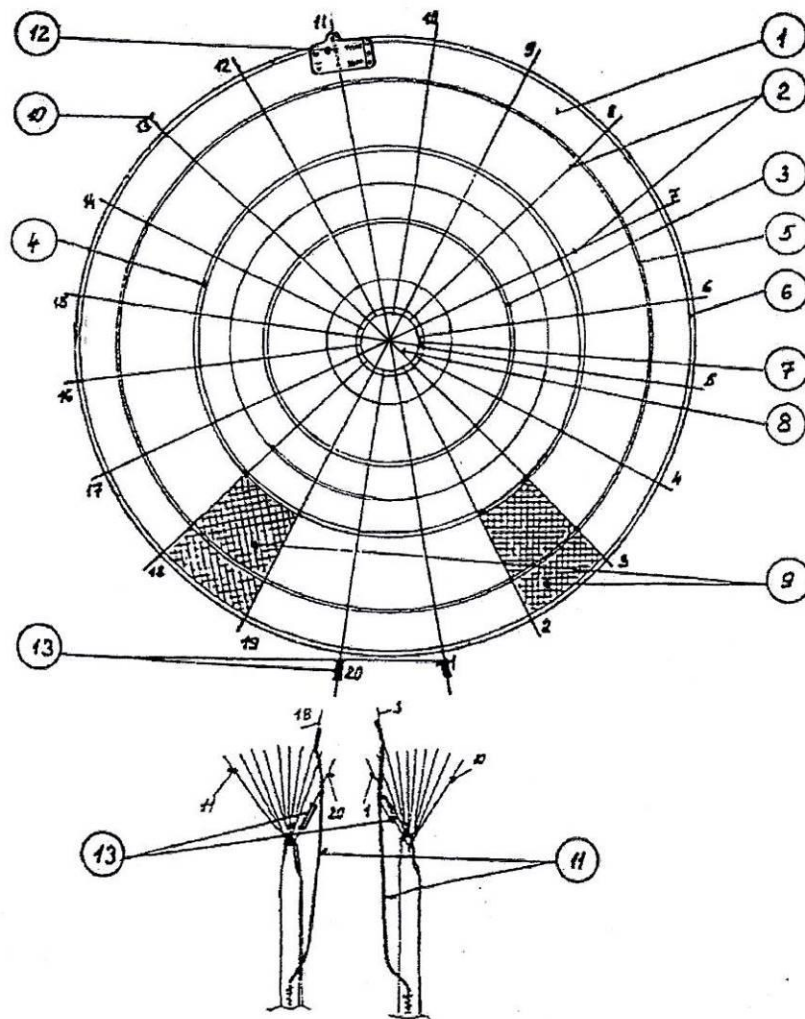

Fig. 4

- 6.4. Harness PS – 041 – 1A
6.5. Container OP – 094 – 1A

The harness with the container forms one unit (fig. 5).

The harness is used for attaching the parachute to the pilot's body and distributing the dynamic impact. The harness comprises of the polyamide strap with minimum breaking strength 27.500 N. It comprises of two main straps – left (1) and right (2), lumbar (3) and chest (4) strap. The main straps are reinforced from the chest straps to the lumbar straps with straps (5), it is transferred into the risers in the shoulder part (6) and in the back straps (7), which are bent and sewn over the lumbar strap (3). The transfer solidity of the main strap into the riser is provided by metal oval lugs (8). The chest part of the left main strap includes the sewn strap (4). One end of the metal hose (9) is sewn and passes in the chest strap for the ripcord wire. Below the chest strap, there is a pocket (10) for placing the ripcord handle. The right main strap in the chest part includes the fastening buckle (11) designed for passing the chest strap and fastening the harness in the chest area. Both reinforcement straps (5) include the sewn ribbon closures (12) from the reverse side designed for setting the length of the harness. The risers are fitted with lugs (13) for connecting the canopy lines. The lumbar strap is on both ends fitted with buckles (14), designed for fastening the harness to the pilot's body. The opening used for passing the main straps is created between two whippings (15) at each end of the lumbar strap. Both main straps, forming the leg straps from the lumbar straps, include the inserted leg pads (16) designed for reducing pressure of the leg straps on the pilot's legs.

The container is designed for placing the canopy with the lines, bridle, and the pilot chute. The container is made of polyamide or polyester fabric in the shape of envelope.

The main parts of the container include: The back cotton pad (17), which is transferred to two shoulder pads (18 central part of the parachute (19) with side flaps (20), closing flap (21), top flap (22)) and lower flap (23).

The back cotton pad includes sewn ribbon closures (24) for connecting the back padding, and the central lower part includes the marking label (25).

The interior part of the back cotton pad forms the container bottom (26), with sewn container central part (19) with side flaps (20).

The centre of the central part includes the sewn cover flap (27), designed for separating the canopy from the harness risers. The central part is fitted with two metal grommets (28) with the passing through closing cord (29) designed for limiting the movement and folding of the pilot chute and for closing the container.

Two side tape loops (30) are sewn to the central part of the container designed for performing the inspection binding of the risers lugs of the harness to the container. Central part of the upper cover flap includes tape loop (31) sewn under the cover flap, designed for connecting the rubber band 2 x $\frac{3}{8}$ " (32).

The closing flap (21) is sewn to the top side of the central part. The closing flap is fitted with two side elastic pockets (33) from the interior side used for the canopy end location with the pole vent cords and then two packaging tapes (34). The centre of the closing flap at the lower edge includes a pressed metal grommet (28). The grommet is designed for passing the rubber band 2 x $\frac{3}{8}$ ", where a part of the bridle is inserted. This method ensures the position of the closing flap with the located end of the canopy top end in the container during the canopy placing into the container.

The lower edge of the central part includes two sewn tapes (35) with passing through rubber bands $1 \frac{1}{4} \times \frac{3}{8}$ " (36), designed for attaching the suspension lines to the container.

Both side flaps (20) are also fitted with metal grommets (28), designed for closing the container.

The lower flap (23) has a pocket shape. It is designed for placing a part of folded canopy.

The central part of the upper edge is fitted with the metal grommet (28) designed for passing the closing cord (29) and for closing the container.

The top flap (22) includes a triangle shape which is transferred to the upper part of the shoulder cotton pad. It is sewn in the interior periphery with the shoulder cotton pads of the back cotton pad. The external connection of the top flap and shoulder cotton pads is provided by the flaps (37).

The top flap comprises of two main parts: External flap (38) and internal flap (39). The external flap in the interior part is fitted with flaps (40) on both sides which are designed for the connection of the external flap to the internal flap, and with reinforcement in the round lower part (41), which is during the parachute completion inserted in the opening in the lower flap. The central part of the external flap is in the central area fitted with the sewn reinforcement (42), designed for the protection of the opening mechanism of the container against external effects.

The internal flap (39) is solidified with reinforcement inside (43) and also fitted with two metal grommets (28), with passing closing cord secured with the ripcord pins during the container packing.

Rectangular cover flap (44) is sewn on the right from the grommets in internal flap and it is designed for covering the opening mechanism of the container (ripcord wire with pins inserted in the closing cord lugs). The cover flap is solidified with reinforcement inside (45) and the longitudinal internal side includes the ribbon closure (46).

Ribbon closure (47) is sewn on the left from the grommets in internal flap.

The ribbon closures enable to connect the non sewn longitudinal side of the cover flap to the internal flap and cover the opening mechanism of the container.

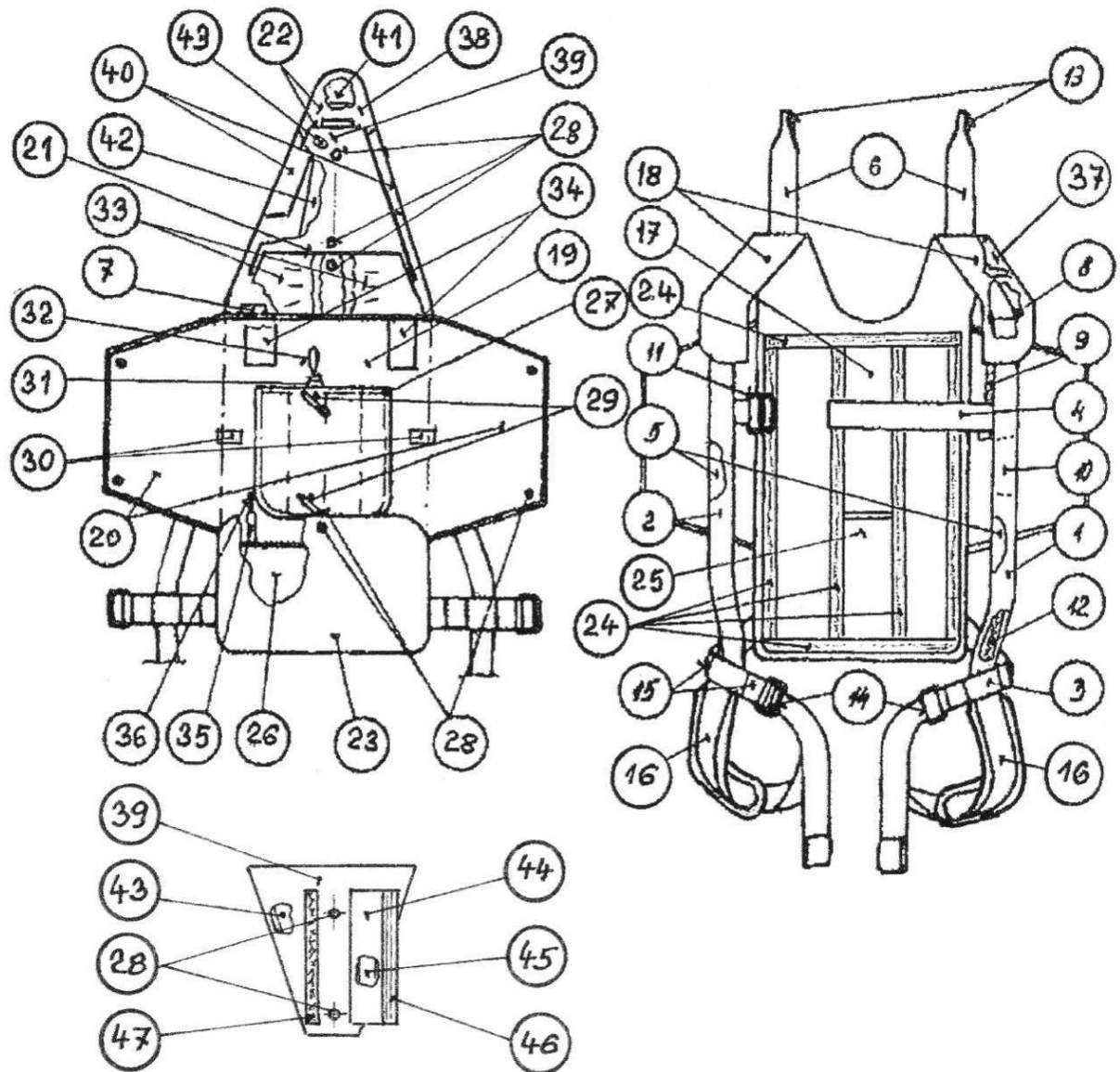

Fig. 5

6.6. Ripcord U – 091 (fig. 6)

The ripcord is designed for closing and opening of the parachute. It comprises of the handle (1), steel wire (2), two pins (3) and a stop (4).

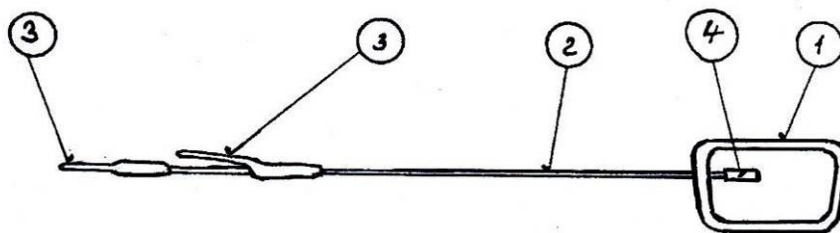

Fig. 6

6.7. Back padding P-032 (fig. 7), Back padding P-030 (fig. 7a)

The back padding is designed for comfortable pilot leaning in the aircraft seat.

The external parts of the back padding P-032 are made of cotton canvas (1) and airtight polyamide fabric (2), interior area is fitted with the padding from unwoven textile (3). On the reverse side of the back padding are sewn ribbon closures (4), designed for the connection back padding to the container.

On user request available back padding P-030 with progressive shape construction for increase user comfort. The external parts of the back padding are made of 3D fabric (1) and of cotton canvas (2). Interior area is fitted with the padding from unwoven textile (3) and from anatomical shape padding (4). On the reverse side of the back padding are sewn ribbon closures (5), designed for the connection back padding to the container.

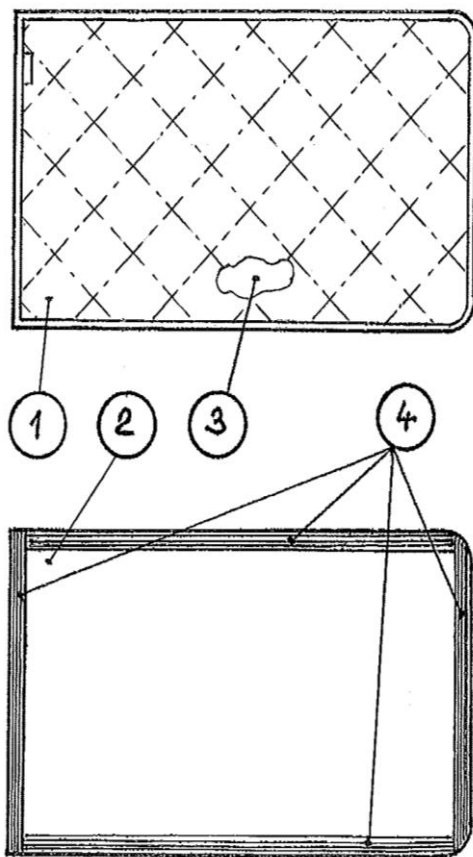

Fig. 7

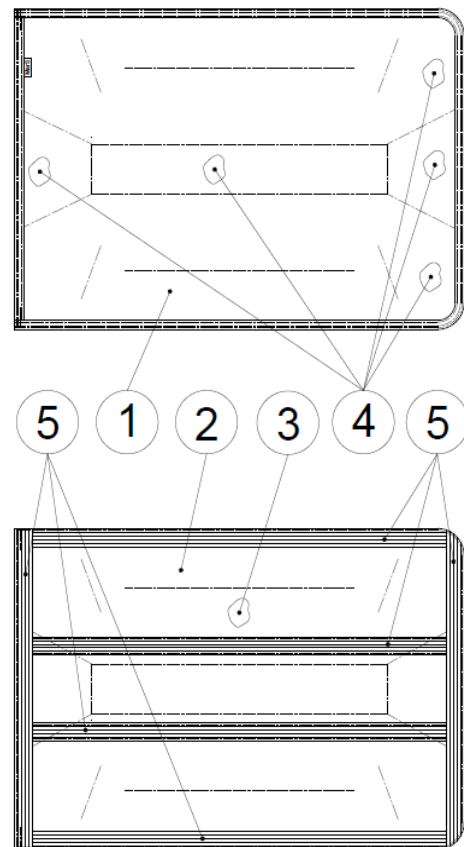

Fig. 7a

6.8. Portable bag G – 225 (fig. 8)

The portable bag is designed for placing the parachute for storage and transport. It is made from polyamide canvas in the shape of a block with dimensions 550x400x170 mm. The upper part of the bag includes a zip (1), for closing the bag. The portable bag includes two holders (2) and a pocket sewn on the side (3), which is closed by means of ribbon closure (4). The pocket is used for locating the parachute logbook and the spare parts.

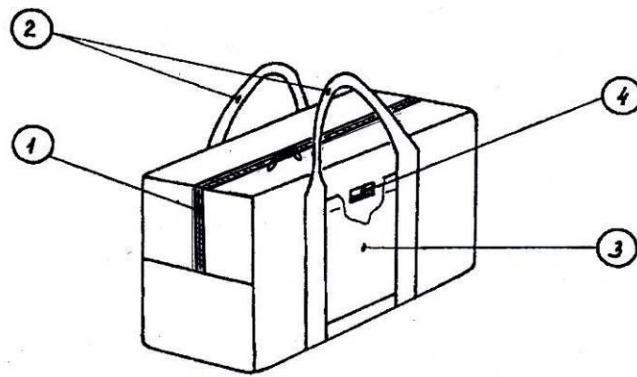

Fig. 8

CHAPTER II.

Instructions for the packing of the parachute

1. General instructions

- 1.1. The parachute can only be packed by a person authorized to pack the parachutes.
- 1.2. Prior to the parachute packaging it is necessary to check the completeness and technical state.
- 1.3. Defects are eliminated by replacing defective parts or by repairing them.
- 1.4. The parachute repair is performed as per the technical conditions for repair works No. O-1-15.
- 1.5. The parts replacement and repairs must be recorded in the parachute logbook.
- 1.6. The sealing of ripcord pins will be completed by means of green threads with 4.5 to 7.5 N strength.
- 1.7. The sealing of risers of the harness to the side loops inside the container and portable bag closing will be completed by means of red threads with 49 to 68.8 N solidity.
- 1.8. During the parachute packing, we recommend to protect the canopy from direct sunlight.

2. Inspection of the parachute before packaging

- 2.1. The inspection is completed in the sequence below:
 - Pilot chute
 - Bridle
 - Canopy with lines
 - Harness
 - Container
 - Ripcord
 - Back padding
 - Portable bag
- 2.1.1 Inspection of the pilot chute
Check the fabric, seams, and metal grommets on the tapes for damage. If the spring is seriously damaged or broken, the pilot chute is replaced with new one.
Check the tapes for sewing with the metal grommets to the spring and their position in the spring base centre.
- 2.1.2. Inspection of the bridle
The cavity strap and sewing are checked for damage.
- 2.1.3 Inspection of the canopy
The canopy is checked stretched against the light. Check the fabric, tapes and sewing for damage. After the canopy inspection, check the suspension and steering lines.

- 2.1.4 Inspection of the harness
Check the harness for the completeness of the straps and sewing, the ripcord pocket, the state and function of the buckles.
- 2.1.5 Inspection of the container
Check the fabric, tapes and reinforcement, the state of metal grommets for damage. Pay extra care to the closing cord – if damaged, it must be replaced.
- 2.1.6 Inspection of the ripcord
Check the ripcord state – the wire, stop and pins (pressing, corrosion, indentations). The damaged ripcord is replaced.
- 2.1.7 Inspection of the back padding
Check the fabrics, tapes and ribbon closures for damage.
- 2.1.8 Inspection of the portable bag
Check the fabric (stains), holder straps and the state of zip for damage.
- 2.2 Damaged parts replacement
The operation enables to replace the parts defined in CHAPTER I, article 5.

3. Packaging tools

- 3.1 The parachute is packed on the packing table or on the field packaging desk.
- 3.2 The parachute packaging requires the use of two packing cords of 1 m length and several weights.

4. Parachute package

The parachute is packed by one person.

After the parachute packing, make a record on the packaging into the parachute logbook.

Packaging procedure:

- 4.1 Packing preparation
- 4.2 Canopy folding
- 4.3 Inspection of the canopy and the lines
- 4.4 Placing of the lines into the closing flap
- 4.5 Inspection of the lines placing
- 4.6 Placing of the canopy into the container
- 4.7 Placing the pilot chute and closing the container
- 4.8 Check of the packed parachute

4.1. Packing preparation

The parachute is spread on the packing table. The cords of the pole vent are attached at the end of the packing desk, the canopy and the suspension lines are stretched at full length. The pilot chute is placed next to the canopy. The harness with the container is placed with the container upwards, the canopy is divided to halves in such way the lines No. 1 to 10 were placed on the right and the lines No. 11 to 20 on the left (fig. 9).

Pass the ripcord wire with the pins through the ripcord hose. The ripcord handle is placed into the pocket on the harness and secured by means of the ribbon closures.

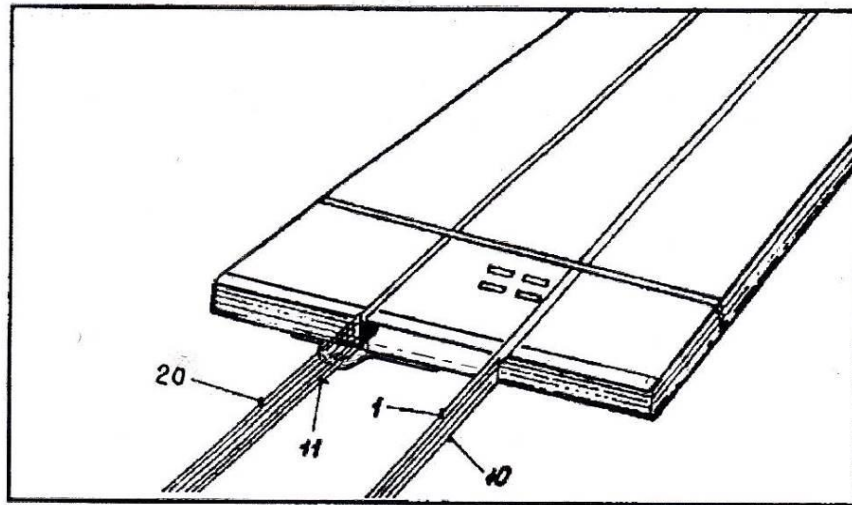

Fig. 9

4.2. Canopy folding

The left half of the canopy is thrown over the right side (fig. 10). Line No. 12 is placed on the Line No. 11, the field between the lines is folded to half and levelled at full length (fig. 11).

This enables is placed of the whole left canopy side up to the line No. 20 (fig. 12).

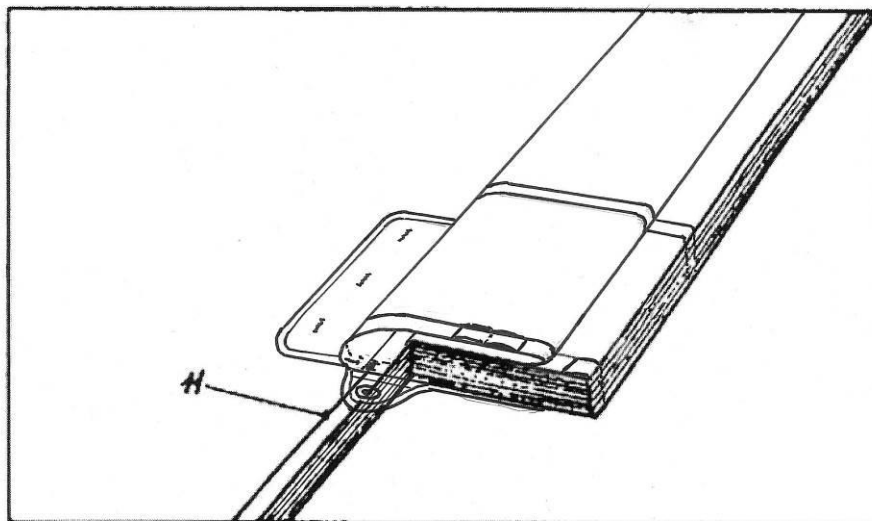

Fig. 10



Fig. 11



Fig. 12

The unfolded right half of the canopy is thrown over the folded left side (fig. 13) and folded identically to the left half (fig. 14). The field between lines No. 1 and 20 is placed to the left.



Fig. 13



Fig. 14

The canopy at the lower edge is folded from the lines at an angle 45° (fig. 15a) and the left and right half of the canopy is folded to one half (fig. 15b).

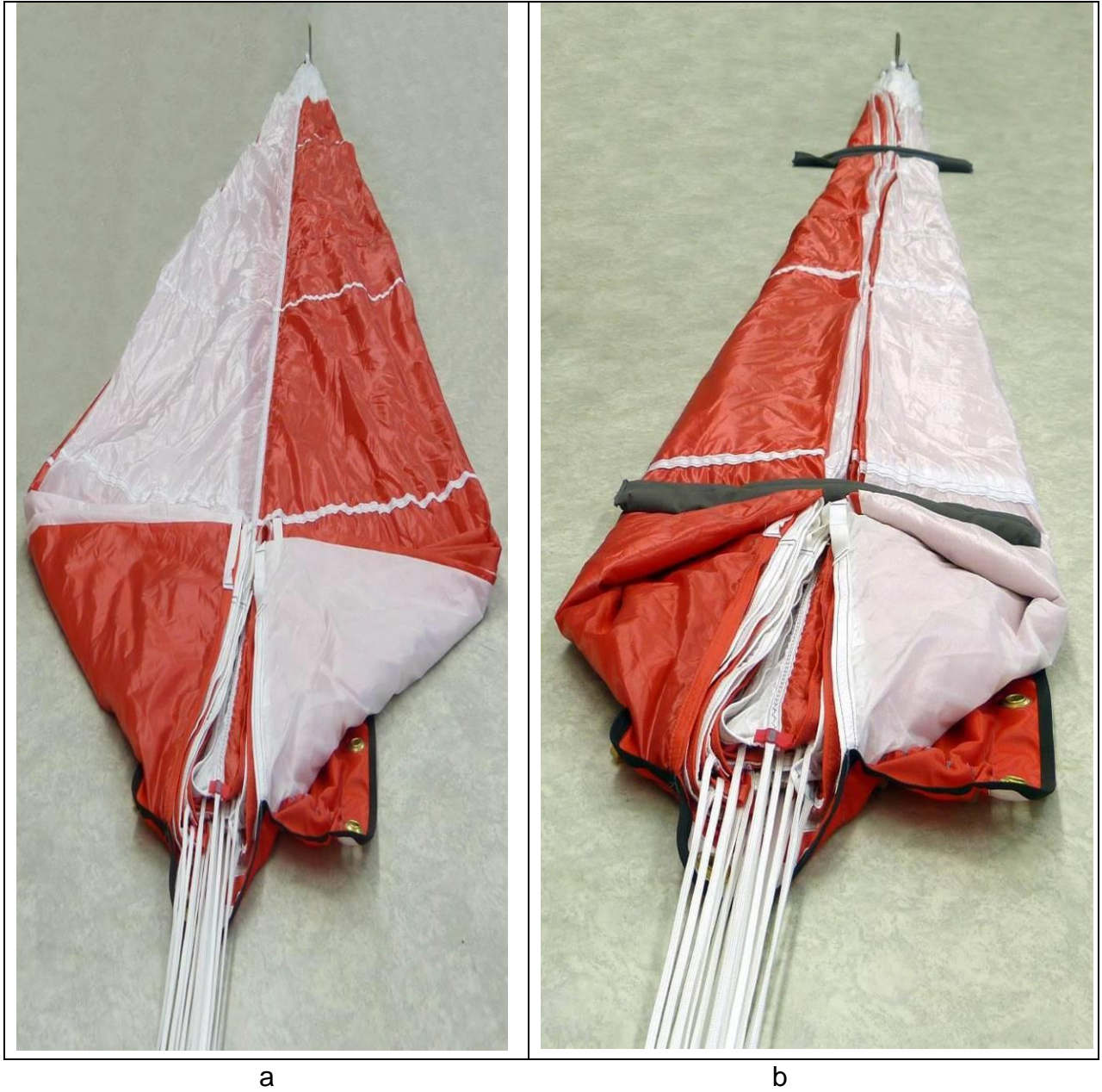

Fig. 15

Such folded canopy is folded to thirds in such way that the canopy right side is placed and then the left canopy side on top, and the canopy is secured with weights (fig. 16).



Fig. 16

4.3. Inspection of the canopy and the lines

The packaging employee holds the lines No. 1 and 20 (at the canopy and the risers, marked red) lifts it and moves from the canopy to the risers of the harness.

This enables to check the free lines from the canopy edge to the risers of the harness (fig. 17).

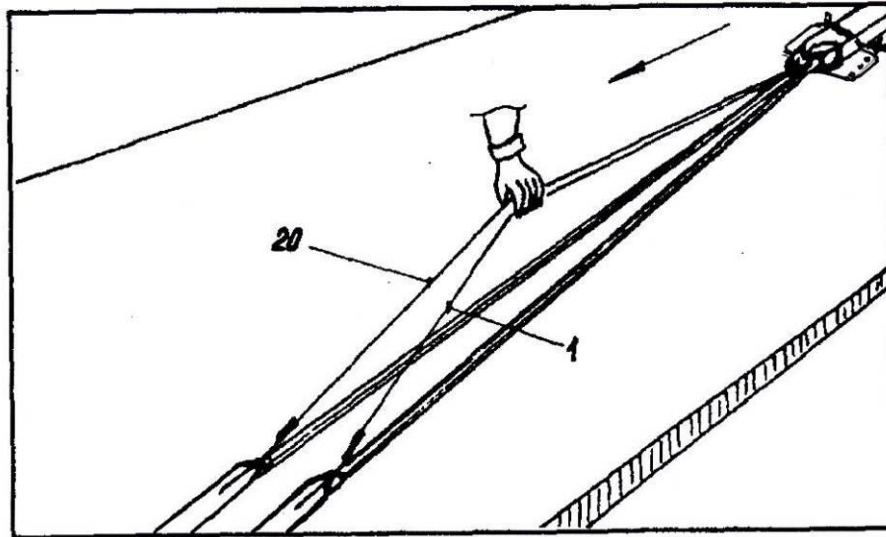

Fig. 17

4.4. Placing of the lines into the closing flap

The process for the suspension lines placing is depicted on figure 18a to 18f.

The suspension lines are held at the lower canopy edge and bent as per figure 18a.

The right side of the closing flap is bent over its left side and the rubber bands on the left side of the closing flap are passed through the openings in the metal grommets in the right side of the closing flap - fig. 18b. The front side of the closing flap is bent over the connected side flaps and the rubber band is passed through the metal grommet of the front side of the closing flap – fig. 18c.

The suspension lines are gradually placed in all three rubber bands, connecting the side and front side of the closing flap (fig. 18d, e) and then to other rubber bands on the right side of the closing flap (fig. 19a, b).

The length of the lugs behind the rubber bands is 30 to 50 mm.

The lines must not be twisted.

During the placing of the suspension lines, the harness with the container is pulled towards the canopy.

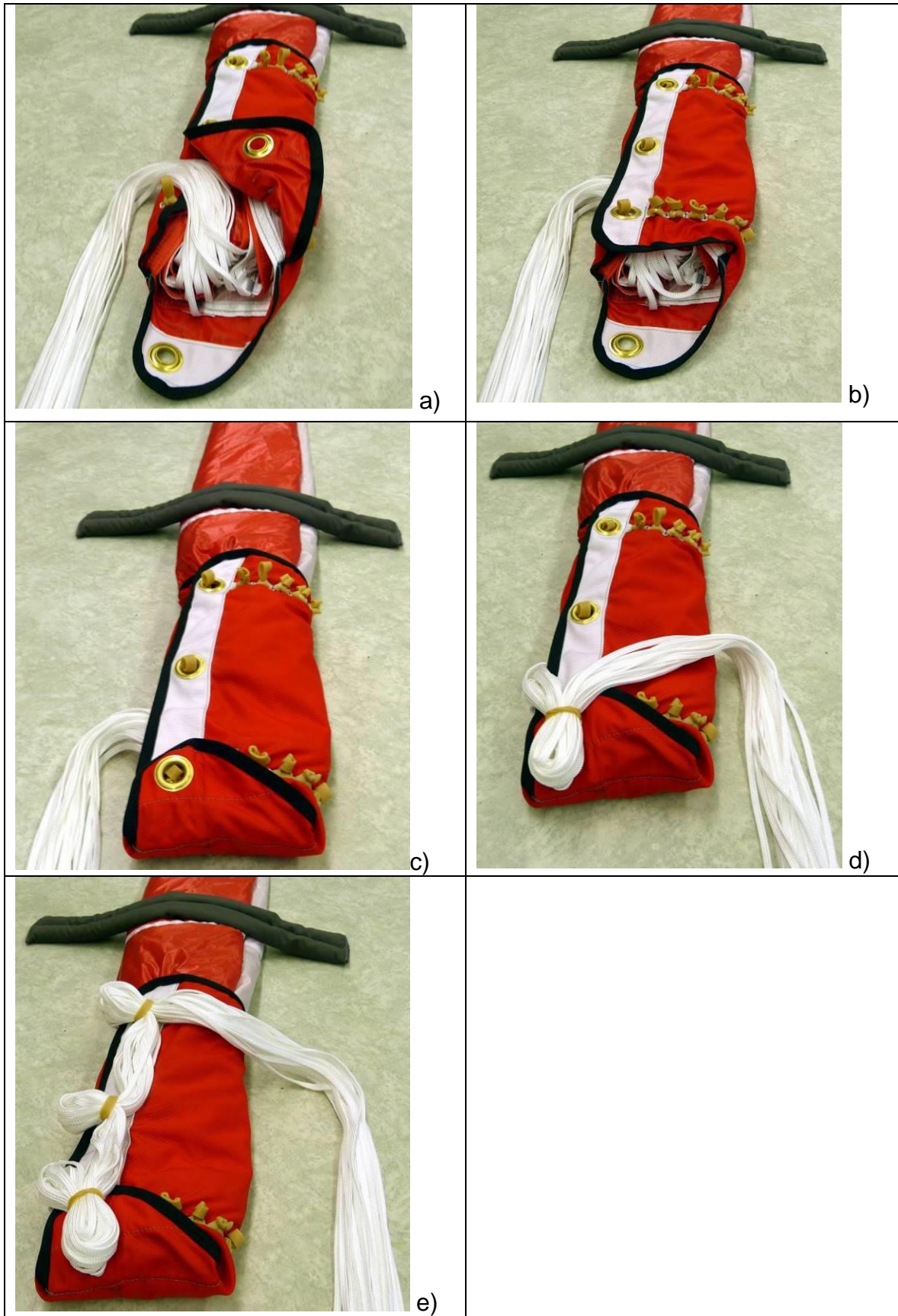

Fig. 18

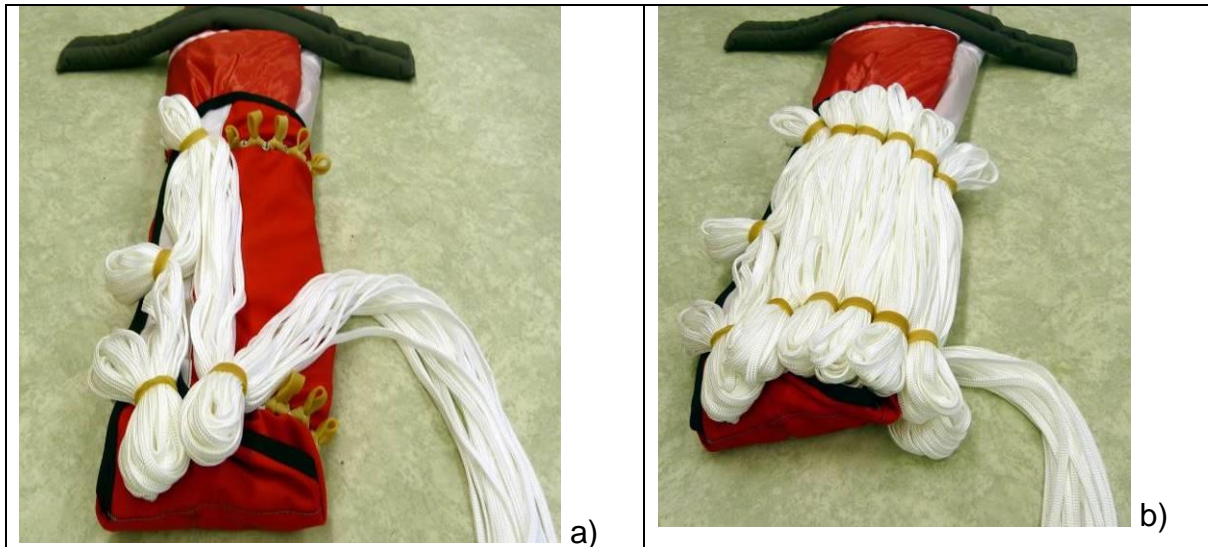

Fig. 19

4.5. Inspection of the lines placing

The packing employee will check the lines placing for correctness.

4.6. Placing of the canopy into the container

Risers of the harness are bent into the container. Attach the red threads with strength 48 to 69 N to the red tape loops, sewn on the sides of the central part of the container (fig. 20).



Fig. 20

Pass one end of the thread through the lug at the end of the riser end and bind it with the second thread end using three nodes. Excess lengths of the threads are cut at distance 15 to 20 mm from the nodes (fig. 21). The same task is performed for the second riser.



Fig. 21

Within compliant distance from the risers, pass the lines through the rubber bands at the container bottom (fig. 22).



Fig. 22

The lower part of the canopy with the placed lines is bent crosswise with the container and attached to the lower flap edge (fig. 23).



Fig. 23

Such prepared canopy is then inserted into the area below the lower container flap (fig. 24).

Pass the auxiliary packing cords in the closing cord lugs.



Fig. 24

The auxiliary packaging cord passes through the metal grommet in the flap lower part.

The packaging continues by inserting the canopy into the area between the closing cord lugs (fig.25).

The remaining part of the canopy is placed in S-shape above the closing cord lug, until the whole area of the container bottom is filled.



Fig. 25

Part of the canopy below the upper edge is placed in S-shape into the elastic pockets on the cover flap – at first in the pocket on the left side of the cover flap, then to the pocket on the right side of the flap in such way the upper edge with the pole vent cords remained out of the pockets (fig. 26).



Fig. 26

The rubber band connected to the tape loop in the upper part of the container bottom passes through the grommet in the cover flap centre, and it is secured by inserted double folded bridle (fig. 27).



Fig. 27

The bridle is placed in layers between the closing cord lugs (fig. 28).



Fig. 28

4.7. Placing the pilot chute and closing the container

The auxiliary packing cord passes out from the metal grommet in the lower flap. The pilot chute with the stop is placed on the folded bridle and the auxiliary packaging cords are passed through the tapes with inserted metal grommets in the lower part of the pilot chute. Use the auxiliary packing cords to pull up the closing cord lugs which are secured by means of packaging mandrels (fig. 29).



Fig. 29

The auxiliary packing cords are passed through the tapes with metal grommets in the top part of the pilot chute, the pilot chute springs are pressed, the textile of the canopy is placed in the centre direction between the spring threads, and the closing cord lugs are pulled out by means of auxiliary packing cords, the closing cord lugs are then secured with auxiliary packing mandrels. Auxiliary packaging cord at the lower cord of the container is then passed through the metal grommet in the lower flap and pulls out the closing cord lug secured with auxiliary packaging mandrel (fig. 30).



Fig. 30

The auxiliary packing cords are passed through the metal grommets in the right side flap and it pulls out the closing cord lugs which are secured by means of the packing mandrels (fig. 31).



Fig. 31

The auxiliary packing cords are passed through the metal grommets in the left side flap and it pulls out the closing cord lugs which are secured by means of the packing mandrels (fig. 32).



Fig. 32

Auxiliary packing cords are passed through the metal grommets in the internal flap of the top flap, the top flap is placed to the side flaps, and the auxiliary packing cords are used to pull out the closing cord lugs, where the ripcord pins are inserted, which closes the container. The auxiliary packing cords are fastened below the ripcord pins and pulled up in such way to prevent the closing cord damage (fig. 33).



Fig. 33

4.8. Check of the packed parachute

The packing employee with check the packed parachute and secure both ripcord pins with green sealing thread with strength $4,5 \div 7,5$ N. The thread passes through the closing cord lug and behind the pressed pin part, the thread ends are tightened with three nodes. The thread ends are bound together at 20 to 30 mm from the nodes and the node is secured with paper adhesive tape (fig. 34).

The adhesive tape is marked: With the date of packaging, the packaging validity, the signature of the packing personnel, and the number of authorization of the packaging employee.



Fig. 34

The closing mechanism is covered with the cover flap by means of ribbon closure and the divided top flap is closed on two sides by means of the side flaps and its lower part is inserted into the opening in the lower flap (fig. 35).

The parachute packing is completed.

The packer shall make a record into the parachute logbook and this entry shall be signed.



Fig. 35

CHAPTER III

Instructions for using the parachute

1. Preparation of the parachute before flying

Prior to the flight, the pilot will check the placing of ripcord pins in the closing cord lugs, the sealing thread for no damage, and the date of the parachute packing.

It is also necessary to check the state and function of the parachute metal parts.

After the parachute fitting, it is necessary to adjust the length of the straps by means of buckles on the harness.

2. Parachute opening

See CHAPTER I. article 3 – The parachute function.

Specialist inspection must be completed upon using the parachute (opening).

If the parachute is damaged during the use, it must be sent for repair to the organisation authorized to perform the maintenance.

CHAPTER IV

Storage and transport of the parachute

1. Preparation of the parachute for storage

Prior to the parachute storage, it is necessary to check it, potentially repair, replace the damaged parts and provide ventilation.

The parachute is stored in the portable bag in packed (within 365 days from packaging) or in unpacked state. The unpacked canopy is levelled according to the fields, and the left part of the canopy is folded to the right side, and the canopy is folded to the lower end.

The suspension lines are folded in chain.

The parachute is inserted to the portable bag in such way the label with the serial number on the back pad of the container was at the top.

The parachute logbook is placed into the pocket on the portable bag.

2. Storage of parachutes

The parachute is stored in shelves in a dry, dark, well ventilated room without direct sunlight. The distance of the lower shelf from the floor must be at least 0.15 m, the distance of the shelves from the walls must be at least 0.5 m, and at least 1 m from the heating units. If the parachutes are stored for longer period, they must be aired at least once after every 365 days for the continuous period of 24 hours. Ventilation is completed in shade, without direct sunlight.

A record on the ventilation is made in the parachute logbook. It is prohibited to store metal objects, which are not a part of the parachutes, oils, acids, thinners and other aggressive substances in the rooms where the parachute assembly is stored. The conditions in the rooms with long-term storage of parachutes are defined by the manufacturer for the climatic conditions below:

- | | |
|-------------------------------|-------------------------|
| - daily temperature | from + 14 až to + 24 °C |
| - daily relative air humidity | from 35 to 73 %. |

The parachute storage and their accessories in the storage is for their lifetime, upon the compliance with the storage conditions defined above.

3. Parachute transport

- 3.1. The parachutes in the operating conditions are transported packed or unpacked in the portable bags
- 3.2. The parachutes must be protected before unfavourable impacts of weather, damage, contamination and before direct sunlight.

CHAPTER V

Maintenance and repairs of the parachute

1. Parachute maintenance

Contamination (sand, mud, soil, etc.) on the parachute parts resulting from operation must be cleaned mechanically (such as by means of a brush, dusting). Contamination impossible to remove mechanically can be washed in tepid water with soap or detergent. Washed parts must be dried in the designated location. It is not permitted to use agents containing chlorine and organic solvents.

Metal parts do not require maintenance upon observing the operation, storage and transport conditions. In case of contamination, metal parts are cleaned with fabric.

Potential damage of the surface protection can be painted with a paint of suitable shade.

2. Parachute repair

The parachute repair is performed for the purpose of further parachute use.

The user can replace the worn parts or damaged parts which are defined in the list of replaceable parts in chapter I, point 5 of this Operation and maintenance manual.

The user will send the parachute requiring repair work with the parachute logbook for repair to authorized repair shop by the manufacturer or to the manufacturer.

He repairs of parachute and the replacement of damaged parts must be recorded in the parachute logbook.

The label completion and marking of the emergency parachute
ATL – 88/90 – 1A (ATL-15)

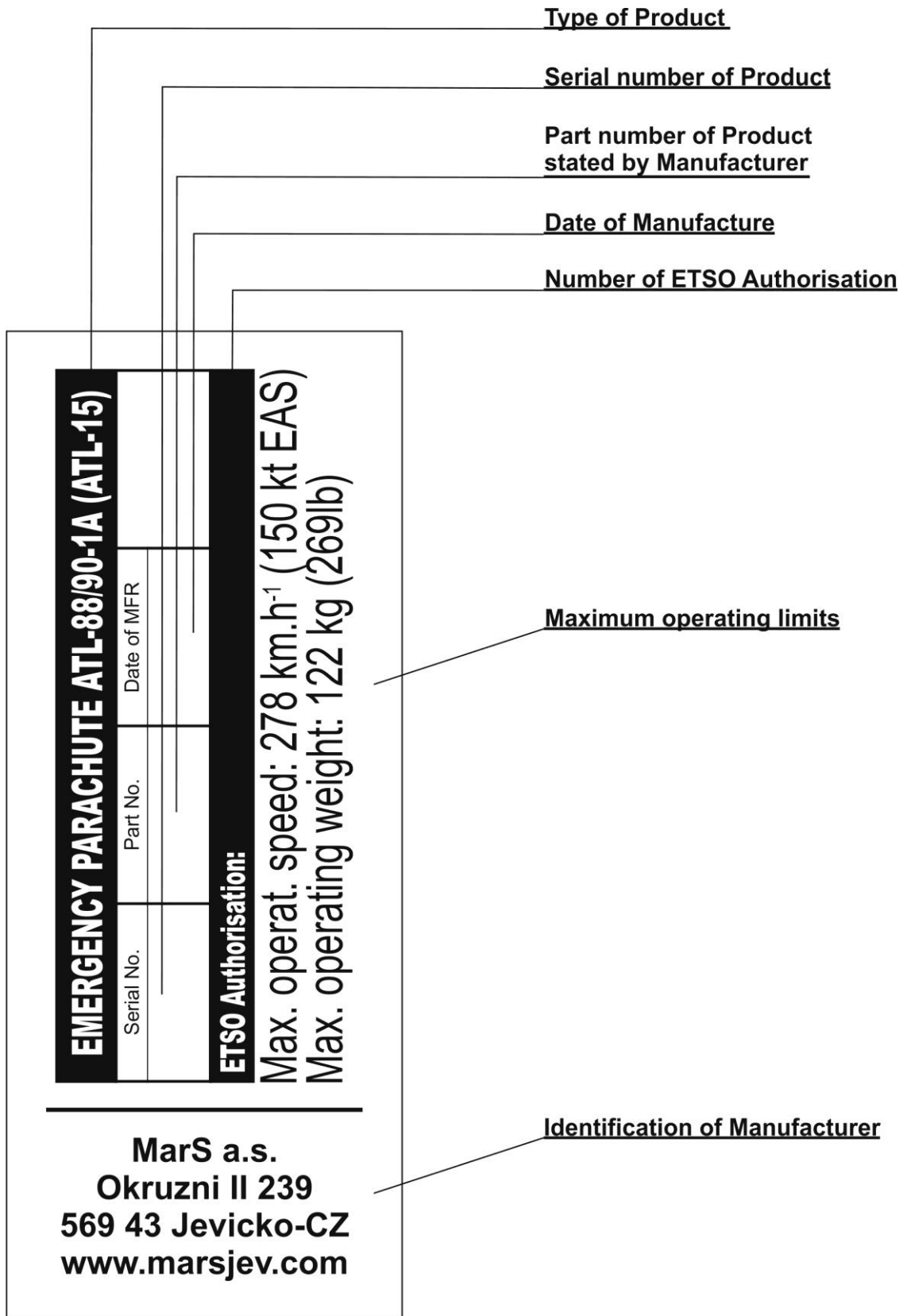



2018

Producer:

MarS a.s., Okružní II 239, 569 43 Jevíčko, Czech Republic

Telephone #: +420 461 353 841; fax: +420 461 353 861

http:\\www.marsjev.com, e-mail: mars@marsjev.cz