



# Preliminary Argus installation guide

## Index

### 1.0 The Argus

- 1.1 Installation in General
- 1.2 Technical Information
- 1.3 Jump Modes

### 2.0 Installation the Argus to your Container

- 2.1 Pouch for Processing Unit
- 2.2 Cutter Holder
- 2.3 Control Unit Holder
  - 2.3.1 Using the transparent pocket
- 2.4 Cable placement

### 3.0 Installation into common Containers

- 3.1 Rigging Innovations Inc.
  - Talon 2*
  - Talon FS & Voodoo*
  - Talon FX*
  - Talon 1 & Telesis 1*
- 3.2 Aerodyne Research LLC
  - Icon & Icon Student*
- 3.3 Velocity Sports
  - Infinity*
- 3.4 Parachutes de France
  - Atom*
- 3.5 Mirage Systems
  - Mirage RTS / G3 / G4*
- 3.6 Relative Workshop / United Parachute Technologies
  - Vector II*
  - Vector III / Micron*
- 3.7 Paratec
  - Ultra II & Next*
- 3.8 Performance Variable / Firebird
  - Performance Variable Tandem*
  - Omega & Omega Tandem*
- 3.9 Sunrise
  - Wings*
- 3.10 Basik Air Concept
  - Advanced "in"*
  - Advanced "out"*
- 3.11 Sun Path
  - Javelin / Javelin Odyssey*
- 3.12 Thomas Sport Equipment
  - 1-Pin Tear Drop & Tear Drop FS*
- 3.13 Jump Shack
  - Racer, Racer Elite*

### 4. Packing your Reserve/Container with Argus

- 4.1 Loop material
- 4.2 Argus Loops

- 4.3 Loop washer**
- 4.4 Tools to use**



## **5. Maintenance for the Argus**

- 5.1 Battery replacement**
- 5.2 Water Resistant Filter replacement**
- 5.3 Cutter Replacement**
- 5.4 Software Update**

## **6. Argus Scheduled Service**

- 6.1 ARGUS Scheduled Service**
- 6.2 Battery replacement - sticker**
- 6.3 Warranty period**
- 6.4 ARGUS Service**
- 6.5 Service Locations**
- 6.6 Cost of Scheduled Service**

## **7. Warnings**



## **1.0 The Argus**

The Argus is a 3<sup>rd</sup> generation electronic and pyrotechnic safety device with superior electromagnetic interference shielding. The unit also works as a data logger, as it memorizes most jump parameters.

The Argus includes four jump modes – Standard, Tandem, Novice, & Swoop - which support a wide variety of user requirements.

### **1.1 Installation in general**

The Argus has been designed to be backward compatible with most sport rigs on the market today. It will easily fit in any currently available AAD pouch which is located in the bottom of the reserve container, on the wall separating the main & reserve containers. If necessary, an Argus installation-setup kit can be supplied.

The Argus cutter must be positioned as specified by the container manufacturers' instructions.

The Argus is a rugged safety device. However, be careful when handling the Argus cables. Do not pull at the cables and take care with the remote control window. Please comply with any country-specific regulations concerning the installation of the Argus AAD.

In case of doubt about the exact installation of the Argus, the rig manufacturers' instructions will override this manual.

### **1.2 Technical Information**

The Argus works by measuring air pressure and the rate of change of air pressure, together with other parameters. Air pressure is, of course, the basis of altitude measurement. When the Argus is switched on, it calibrates itself to the ambient air pressure and then memorizes this as its zero or ground level. It re-calibrates regularly, to check for any pressure changes caused by weather, and updates its memory accordingly. Thus, it always knows the latest actual air pressure and its memory is always set to the most accurate zero or ground level. The microprocessor recognizes takeoff in the aircraft when it registers a signature rapid pressure change. Then, it changes to a fast calculation mode in which it evaluates a series of firing criteria at short time intervals. All of these criteria must be positive before the unit will fire. Once the unit passes 500m (1600ft) AGL, it arms itself and becomes fully operational.

NOTE: the Argus will not work if the aircraft is exited before reaching 500m (1600ft) AGL.

Once the aircraft has climbed through this altitude, and the Argus has become fully operational, it will work for any exit altitude. During a descent in the aircraft, in freefall, or under canopy, the Argus will monitor all parameters, all the way to landing. In swoop mode, however, this process is put on standby after an opening is detected. Advanced technology and superior programming are used to eliminate the influence of air vortices. Such vortices can cause erroneous altitude readings varying by more than 100 meters (300 ft) from the actual altitude. You can observe these pressure differences when looking at your altimeter in freefall and turning from a belly down to a belly up position (or vice versa).



The needle will shake and change to a higher (or a lower) altitude. A digital altimeter may indicate a 100 meter (300 ft) difference, just by turning your hand. A precision AAD

must be capable of instantly compensating for a wide range of fluctuations in dynamic pressure. The Argus is programmed to recognize the extremes of vertical velocity and acceleration to which every skydiver can be subjected and uses this information, together with constantly updated pressure measurements. It performs comprehensive mathematical routines, using computational power equivalent to a normal personal computer. Even when Argus is switched off, it is not completely at rest, because it will be checking to see whether or not the push button on the control unit has been pressed.

During the design process, the first priority was to render the release unit as safe and reliable as possible. Nobel Energetics designed the Metron cutter to the Argus specifications. The propellant charge in the cutter is only required to propel the circular blade a distance of 6mm. It does so with enough force to cut through a loop of 185-200 Kg Dyneema or Spectra. You would hardly expect such enormous power inside such a small device! The closing loop is cut instantly, resulting in an immediate reserve opening regardless of the condition of the pin(s). Apart from the push button on the control unit, the cutting blade is the only moving part of Argus.

### **1.3 Jump Modes**

The jump modes describe the conditions required for the Argus activation. All modes except Swoop will monitor the jump until the landing. In Swoop mode, as soon as a parachute opening is detected, the Argus will go to stand-by until the next jump.

**Jump modes are:**

<b>Jump Mode</b>	<b>Trigger Altitude</b>	<b>Trigger Speed</b>
<b>STANDARD</b>	<b>~250 m-820 ft</b>	<b>35 m/s-115 ft/s</b>
SWOOP	~250 m-820 ft	35 m/s-115 ft/s
NOVICE	~300 m-1,000 ft	20 m/s-66 ft/s
TANDEM	~660 m-2,200 ft	35 m/s-115 ft/s

For any particular jump mode, when the altitude and vertical speed conditions are met, the reserve parachute will be activated.

## 2. Installation of the Argus into your Container

### Disclaimer

This manual contains information and instructions on installing Argus in various harness container systems. Where the manufacturer of the harness container system has also issued written instructions for installation, these must be followed. Please, do NOT experiment with installation methods. We shall answer all questions immediately and give advice and assistance wherever possible.

**Please: Never ever install an Argus by trial and error.  
This could cause someone's death!**

We would welcome any constructive comments based on riggers' experience in installing the Argus.

### General remarks

All Argus installations must be done by licensed riggers (US FAA Senior Rigger / Master Rigger or foreign equivalent) using this manual and any written instructions issued by the rig manufacturer.

### When installing the Argus it is vital to ensure that:

- installation is carried out in accordance with the instructions in this manual and any written instructions issued by the rig manufacturer,
- the manual opening system for the reserve (i.e. pins, pack flaps etc.) is not obstructed in any way,
- the structural integrity of the harness is not affected (e.g. by inserting / removing stitching, etc.),
- The grommets are not damaged**
- the processing unit is positioned correctly inside the pre-equipped pouch

## 2.1 Pouch for Processing Unit

The pocket for the processing unit must be fixed inside the reserve container by sewing it to the partition wall. Sew as close as possible to the outer of the two rows of stitches on the binding tape surrounding the pocket. Sew all the way round the pocket. If the pocket is only tacked on or if the sewing is not at the outer edge of the binding tape, there is a danger of the reserve suspension lines becoming trapped.

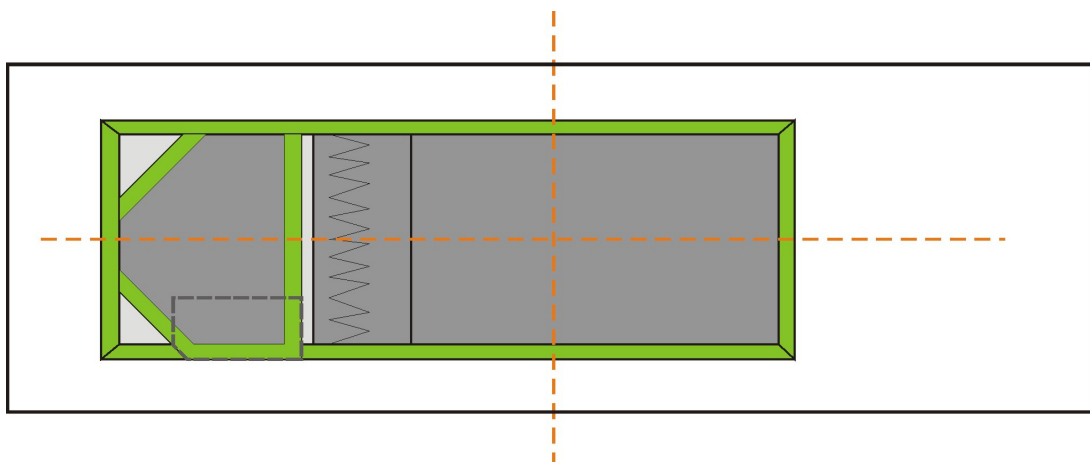



To provide maximum protection for the processing unit (against physical damage and extremes in outside air temperature), the pocket must be positioned so that the processing unit sits centrally on the reserve container partition wall.



## 2.2 Cutter-holder

We recommend the use of a “heavy duty” single needle or a double-needle sewing machine to install the cutter holder to the designated flap of the reserve container. These flaps are almost always constructed with stiffeners, and it is important to test the ability of the sewing machine to sew through the required layers before using it on the actual container.



When a reserve is packed the closing flaps are always under tension and are pulling outwards from the closing loop. The closing loop will therefore always be pulled up against the inside edge of each closing flap grommet. This will always be the edge nearest to the free or tapered end of the closing flap. By aligning the edge of the binding tape with the centerline of the grommet as shown, the cutter will align with the normal loop location when tension is applied to the flaps.

## 2.3 Control unit holder

Installation of the (remote) control unit: just slip the Argus control unit in the clear window, provided by the rig manufacturer.

### 2.3.1 Using the transparent pocket

If the rig manufacturer hasn't incorporated a clear window for the control unit, please use the transparent pocket available from Aviacom.



Install the pocket under the upper right section of the container's closing flap, roughly in the same position as shown on the pictures. Slide the control unit into position from the right side and close the Velcro fastening.

*It may be necessary to make small adjustments to the recommended pocket location to insure metal housings and clamps do not come in contact with the face of the control unit under normal use.*

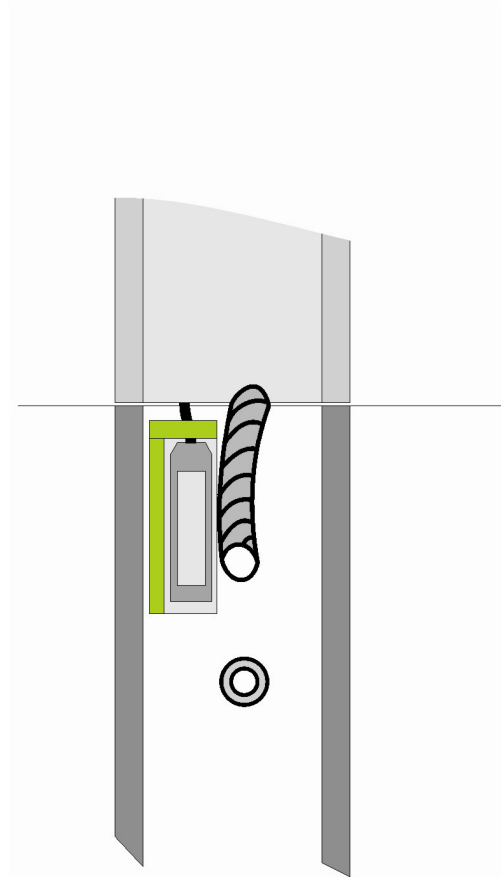

On pop-top containers it could be necessary to mount the transparent pocket under the pin-cover flap in the back of the container

## 2.4 Cable placement

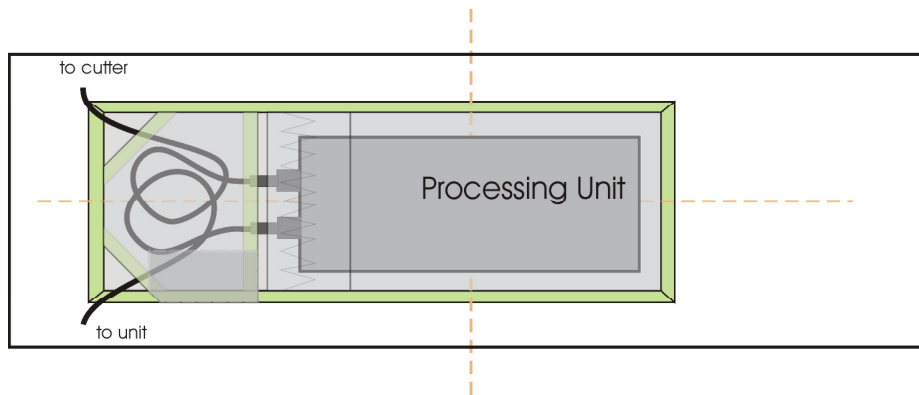

Ensure there are no kinks and coil as loosely as possible while still fitting the processing unit in the pocket. Coils must not be smaller than the diameter of a 25 cent coin. Then, route the cables through the appropriate opening to the control and release units.



### **3.0 Installation into common containers**

**As a general rule, modern parachute containers come equipped with a setup for a modern AAD such as the Argus. Please follow our installation guide to install the Argus AAD. If there is a compatible AAD cutter holder, control unit pouch, or processing unit pouch already installed at the same place as this guideline recommends, it is not necessary to change the parts.**

**If you could not find your harness container-system in this guide, please do not hesitate to contact Aviacom to get updated installation information.**

Check the whole Argus installation for condition and serviceability at each reserve repack. If any damage is discovered, the unit must be returned to an authorized service center. During the warranty period, the repair will be free of charge. In any case, the unit will be returned to the owner promptly after receipt at the service center.

**IMPORTANT NOTE:**

Rapid and careless removal of the pull up cord can cause friction damage to the loop. To avoid damage, remove the pull up cord by pulling it slowly against the underside of the ripcord pin. If, during packing, you need to pass the pull up cord through the loop hole in the release unit you must use the special Argus Dyneema pull up cord supplied, or equivalent Dyneema pull up cord from another manufacturer. This will reduce the possibility of damage to the cutter.

### 3.1 One-pin containers with internally mounted reserve pilot chute

#### 3.1 Rigging Innovations Inc.

Rigging Innovations Inc.  
Po Box 86  
Eloy, AZ 85231  
USA  
Phone +1 - 520-466-2655

#### Talon 2

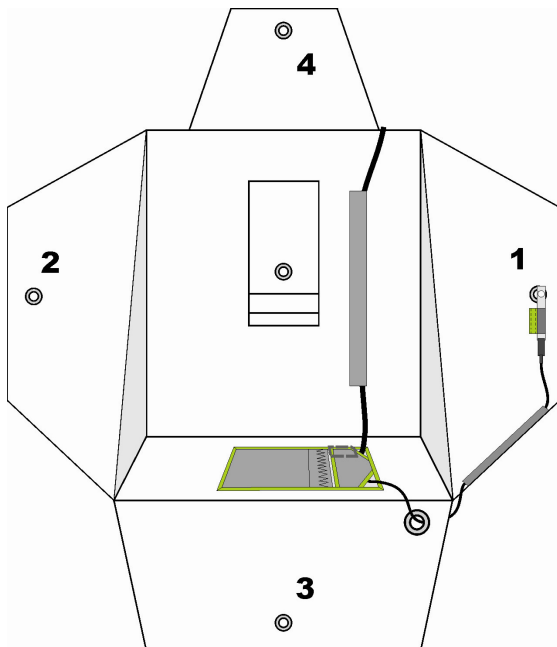

On the Talon 2 container, the cutter is mounted on flap # 1, directly over the reserve pilot chute. Thread the cutter cable through the grommet in flap # 3. Inspect this area of the cable for any damage from the metal surfaces of the grommet.

## Talon FS & Voodoo

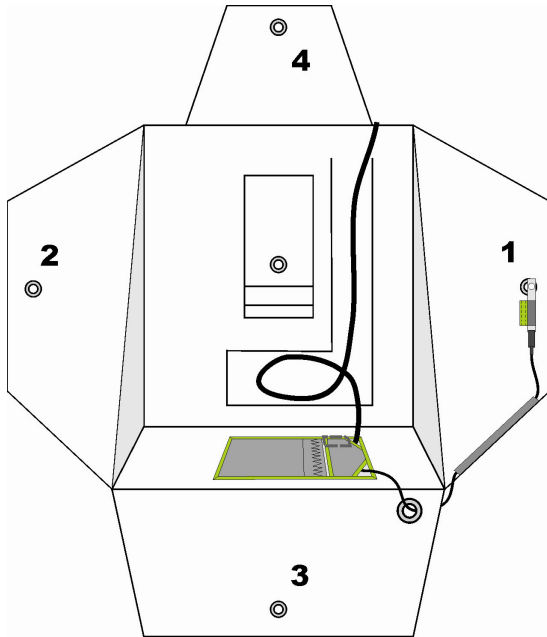

On the Talon FS and the Voodoo container, the cutter is mounted on flap # 1, directly over the reserve pilot chute. Thread the cutter cable through the grommet in flap # 3. Inspect this area of the cable for any damage from the metal surfaces of the grommet.

## Talon FX

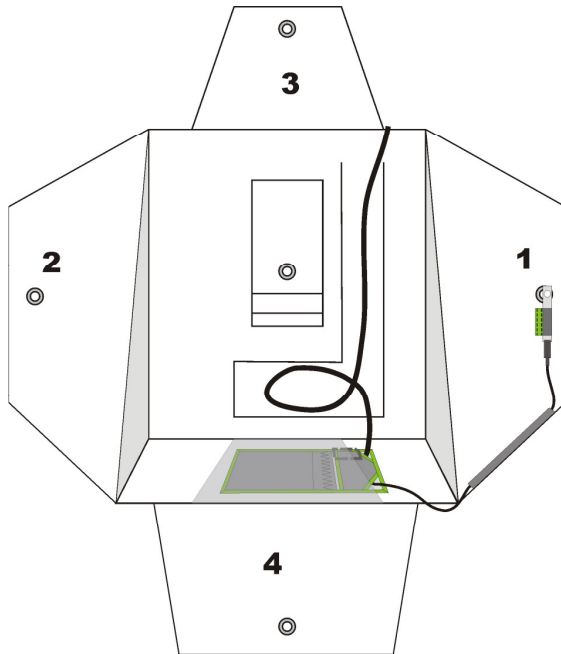

On the Talon FX container, the cutter is mounted on flap # 1, directly over the reserve pilot chute. Thread the cutter cable through the grommet in flap # 3. Inspect this area of the cable for any damage from the metal surfaces of the grommet.

## Talon 1 & Telesis 1

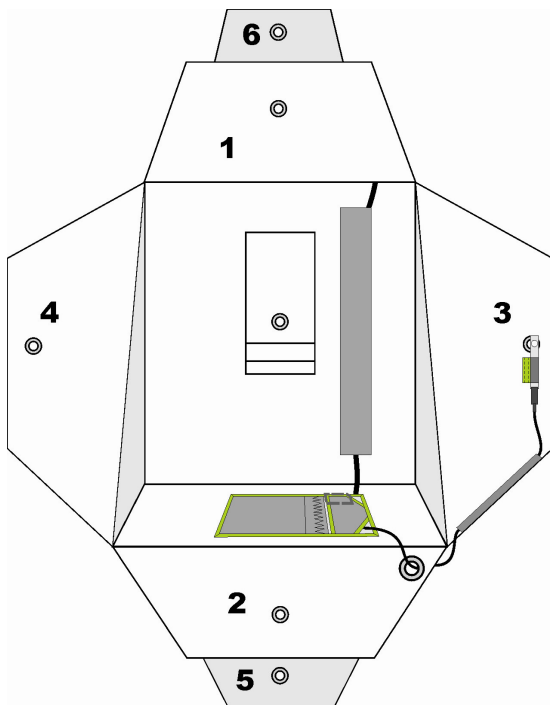

On the Talon 1 & the Telesis 1 container, the cutter is mounted on flap # 3, directly over the reserve pilot chute. Thread the cutter cable through the grommet in flap # 2. Inspect this area of the cable for any damage from the metal surfaces of the grommet.

## 3.2 Aerodyne Research LLC

Aerodyne Research LLC  
12649 Race Track Road  
Tampa, Florida 33626  
USA  
Phone +1 - 813-891-6300

### Icon & Icon Student

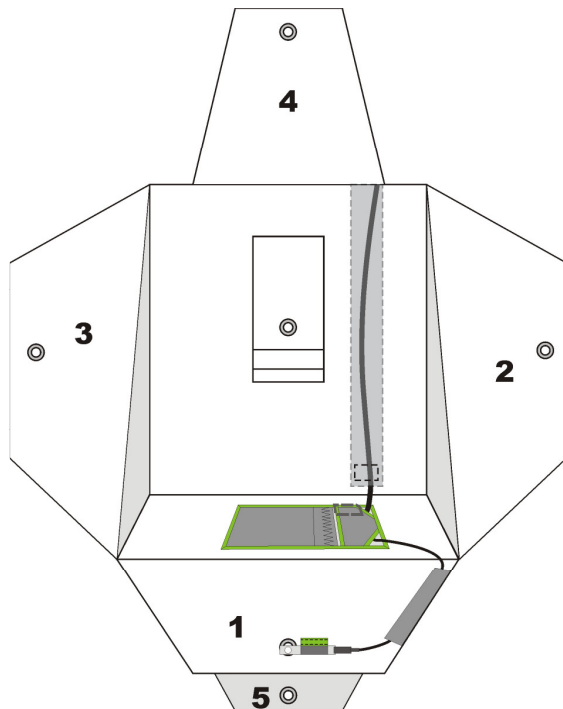

On the Icon and the Icon student container, the cutter is mounted on flap #1, directly over the free bag of the reserve canopy.



### 3.3 Velocity Sports

**Velocity Sports Equipment**  
27611 146<sup>th</sup> Ave.E.  
Graham, WA 98338  
USA  
Phone: +1 - 360-893-6111

### Infinity

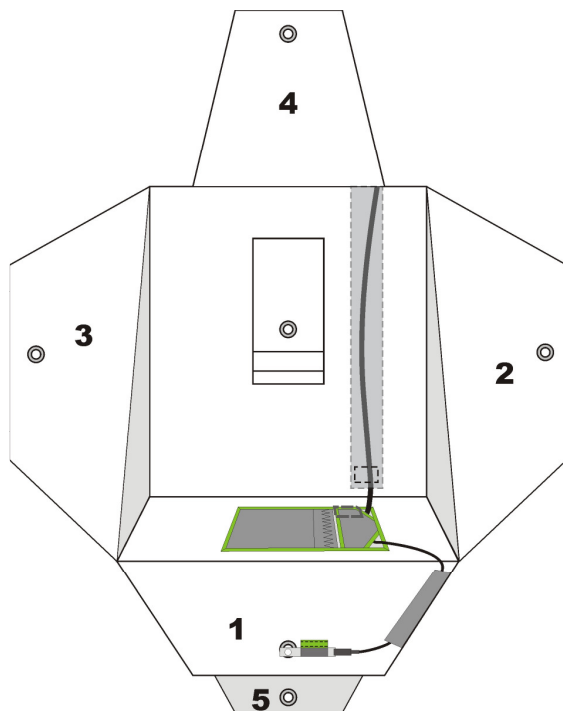

On the Infinity container, the cutter is mounted on flap #1, directly over the free bag of the reserve canopy.

## 3.4 Parachutes de France

Parachutes des France  
2 rue Denis Papin  
Jouy-le-Moutier  
F-95031 Cergy Pontoise  
France

### Atom

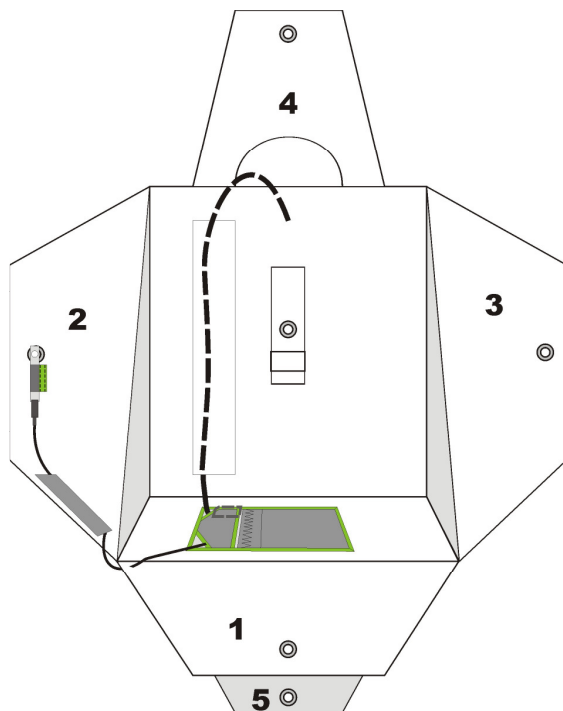

On the Atom container, the cutter is mounted on flap #2, directly over the reserve pilot chute of the reserve canopy.

**NOTICE:**  
Some older models (before 1993) do have a 6 flap reserve container. The cutter on all Atom containers is always mounted to the first flap over the reserve pilot chute.

### 3.5 Mirage Systems

**Mirage Systems, Inc.**  
**1501A Lexington Ave.**  
**Deland, Florida 32724**  
**USA**  
**Phone +1 - 904-740-922**

#### Mirage RTS / G3 / G4

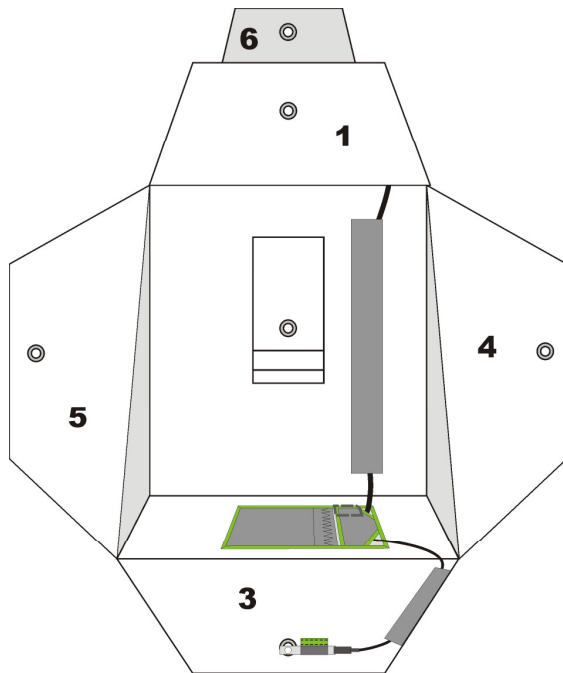

On the RTS / G3 / G4 Container, the cutter is mounted on flap #3, directly over the reserve pilot chute.

The reserve pilot chute cap is marked with # "2" - like a flap.

## Relative Workshop / United Parachute Technologies

United Parachute Technologies (formerly Relative Workshop)  
1645 Lexington Ave.  
Deland, FL 32724  
USA  
Phone +1 - 386-736-7589

### Vector II

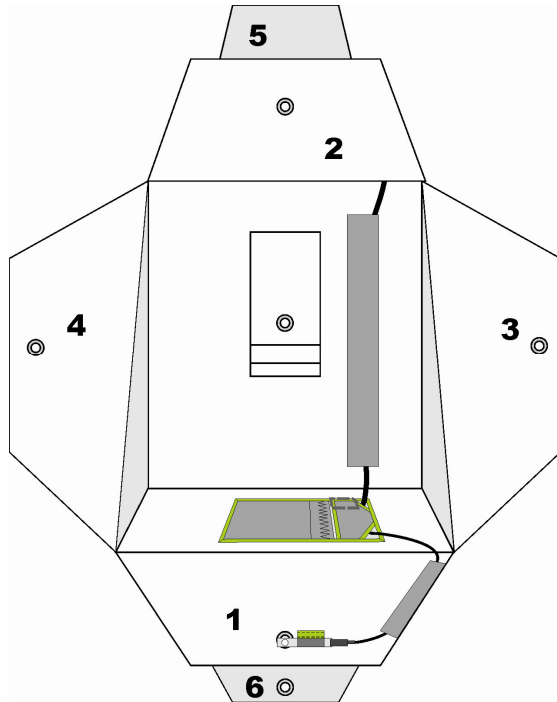

On the Vector II container, the cutter is mounted on flap #1, directly over the free bag.

Notice: Some very old models may have the cutter on flap #3 directly over the reserve pilot chute. You could leave it or change the cutter holder to flap #1.

## Vector III / Micron

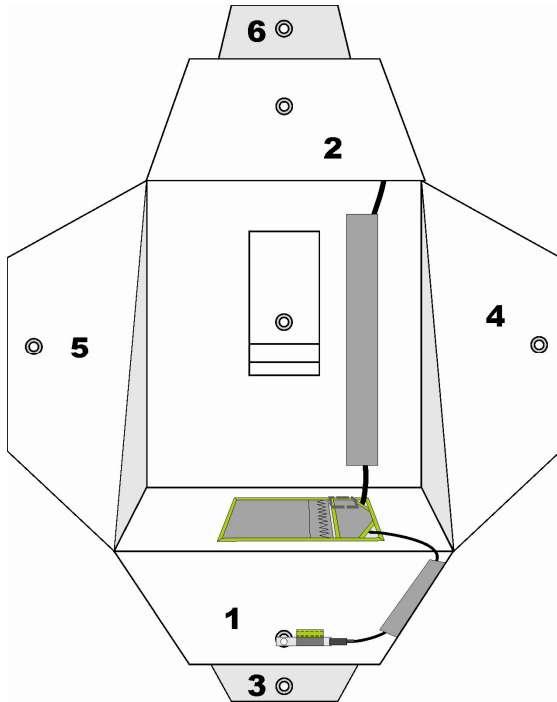

On the Vector III/Micron container, the cutter is mounted on flap #1, directly over the free bag of the reserve.

## 3.7 Paratec

Paratec GmbH  
Flugplatz Saarlouis-Düren  
66798 Wallerfangen  
Germany  
Phone +49- 6837 - 7375

### Ultra II & Next

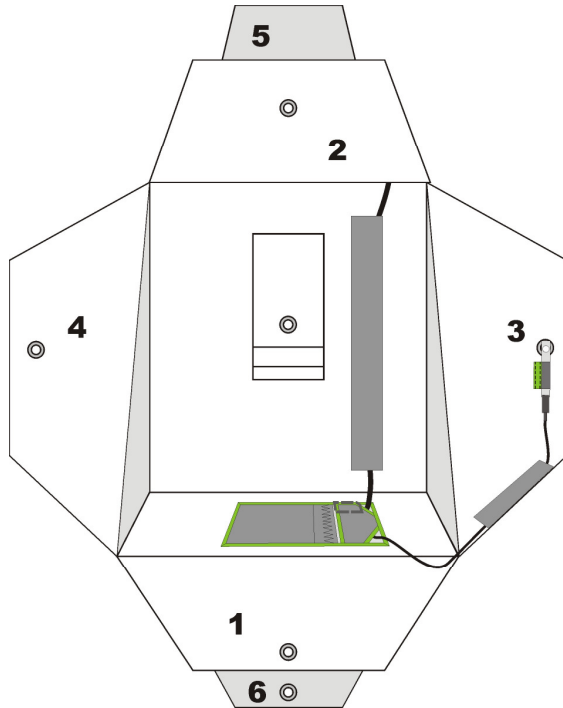

On the Ultra II and the Next container, the cutter is mounted on flap #3, directly over the reserve pilot chute.

## Firebird / Performance Variable

Firebird GmbH & Co KG (formerly PerformanceVariable)  
Am Tower 16  
54634 Bitburg,  
Germany  
Phone +49-6561-949680

## PV Tandem

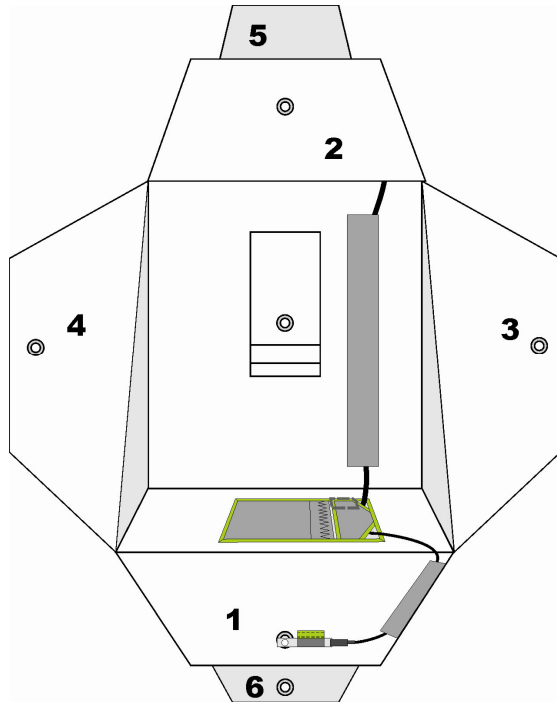

On the Performance Variable Tandem container, the cutter is mounted on flap #1, directly over the free bag.

## Omega Sport & Omega Tandem

on flap #3, directly over the reserve pilot chute.

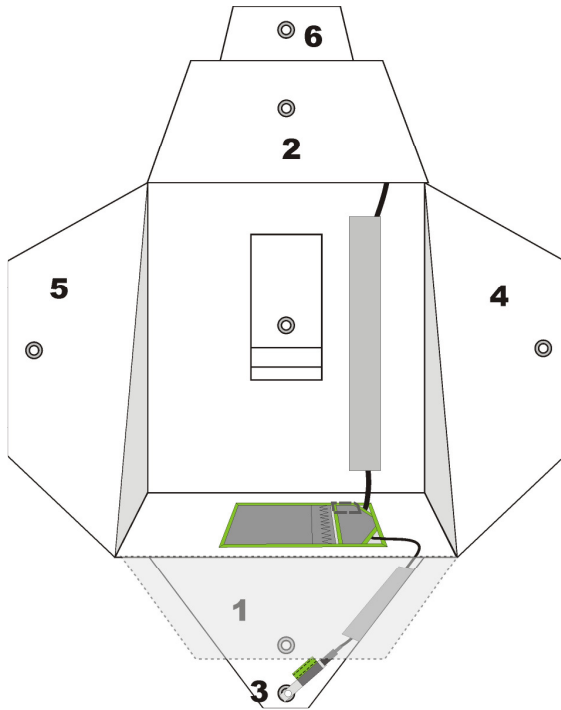

On the Firebird and the Performance Variable Omega Sport container and Omega Tandem, the cutter is mounted



### 3.9 Sunrise

**Sunrise Manufacturing International Inc.**  
6520 Fort King Road  
Zephyrhills, FL 33542  
USA  
Phone +1 - 813-780-7369

### Wings

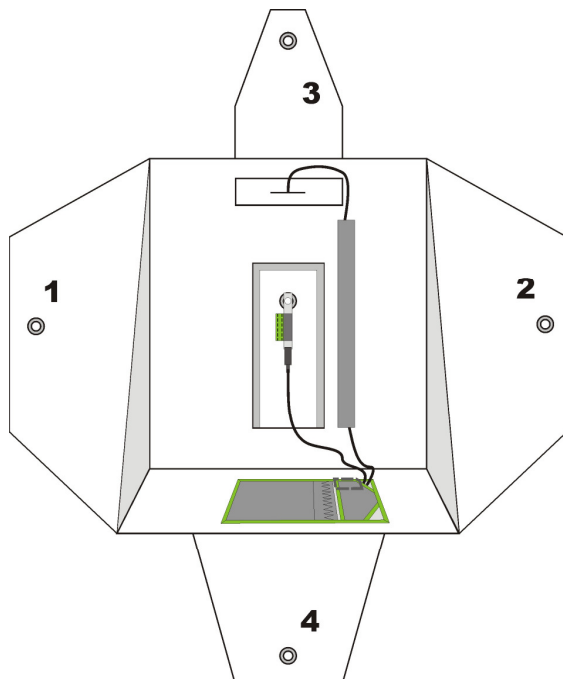

On the Wings container the cutter is mounted directly on the bottom of the reserve container, under the free bag.

### 3.10BasiK Air Concept

**BasiK Air Concept**  
**559 chemin des Salles –**  
**83300 Draguignan**  
**France**  
**Phone: +33 - 494 99 12 36**

#### Advanced “in”

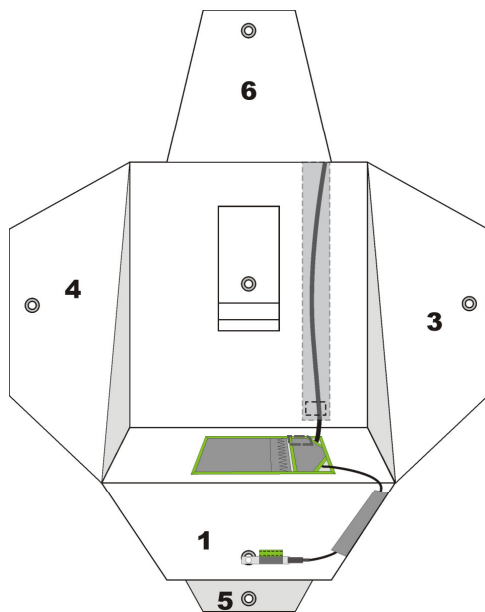

On the Advanced “in” container, the cutter is mounted on flap #1, directly over the free bag of the reserve canopy. The reserve pilot chute is marked as # “2”

#### Advanced “out”

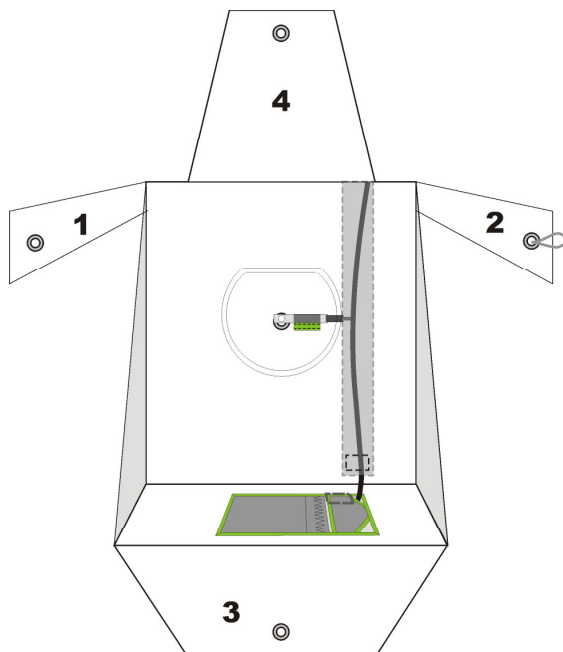

On the Advanced “out” container, the cutter is mounted directly on the bottom of the reserve container, under the free bag.

### 3.11 Sun Path

Sun Path Products  
4439 Skydive Lane  
Zephyrhills, FL 33542  
USA  
Phone +1 - 813-782-9242

### Javelin / Javelin Odyssey

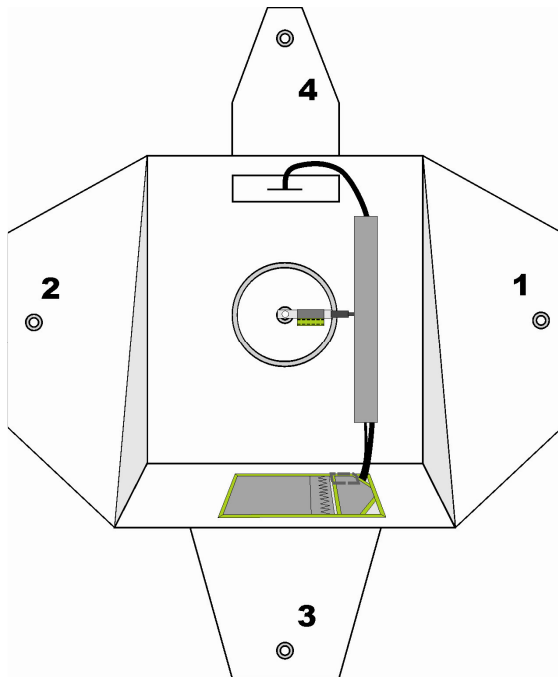

On the Javelin and Javelin Odyssey containers, the cutter is mounted directly on the bottom of the reserve container, under the free bag. Both cables use the bottom half of the same cable channel, before the cutter is routed to the cutter holder.

### 3.12 Thomas Sport Equipment

Thomas Sports Equipment Ltd  
Pinfold Lane  
Bridlington  
United Kingdom  
YO16 6XS  
Phone +44-1262-678299

#### 1-Pin Tear Drop & Tear Drop FS

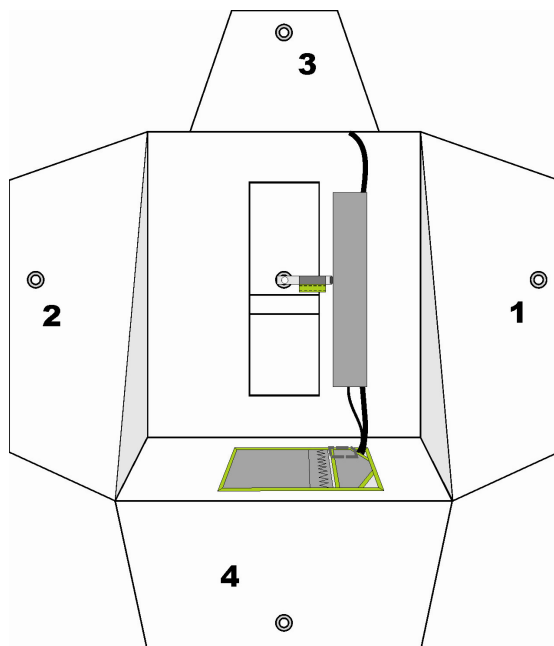

On the 1-Pin Tear Drop and Tear Drop FS containers, the cutter is mounted directly on the bottom of the reserve container, under the free bag. Both cables use the bottom half of the same cable channel, before the cutter is routed to the cutter holder.

### 3.13 Jump Shack

**Jump Shack**  
**1665 N. Lexington Ave. #106**  
**DeLand, FL 32724-2187**  
**USA**  
**Phone +1 - 386 - 734-5867**

### Racer, Racer Elite

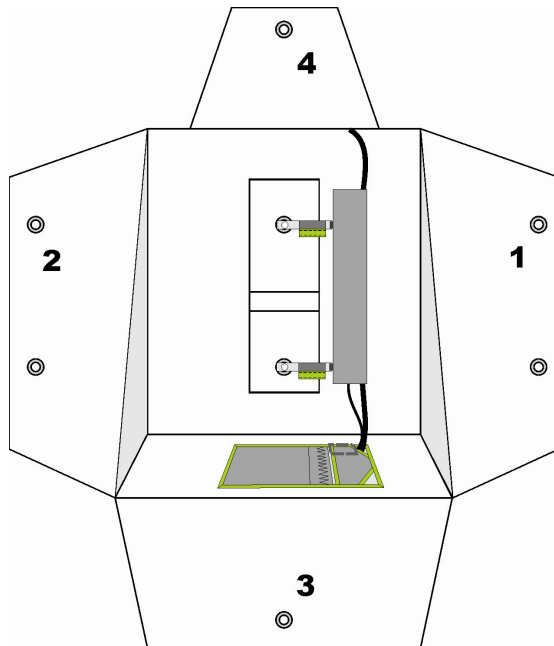

On the Racer and Racer Elite containers, the cutters are mounted directly on the bottom of the reserve container, under the free bag. All cables use the same cable channel in the beginning, before the cutters are each routed to their respective cutter holder.

## **4. Packing your reserve container with the Argus AAD**

Check the whole Argus installation for condition and serviceability at each reserve repack.

### IMPORTANT NOTE 1:

Rapid and careless removal of the pull up cord can cause friction damage to the loop. To avoid damage remove the pull up cord by pulling it slowly against the underside of the ripcord pin.

When you need to pass the pull up cord through the loop hole in the cutter you must use the special Argus Dyneema pull up cord supplied, or equivalent Dyneema pull up cord from another manufacturer. This will reduce the possibility of damage to the cutter.

Argus loops should never be shorter than those normally used on any particular rig. When the cutter is mounted on the bottom of the reserve container, the loop(s) should be of normal length for the rig in question. Do not shorten them unnecessarily as this causes extra tension and could lead to premature loop failure. When the cutter is mounted on one of the reserve closing flaps the loop should be lengthened by up to 1cm in case of a one-pin container, and up to 2cm in case of a 2-pin container to allow for the diameter of the cutter body. Before attaching the loop to the disc, stretch it by pulling on both ends at least twice. Pulling force is what matters, not the duration of the pull. A short but decisive pull will do. When the loop has been tied to the disc, repeat the procedure. A 2-pin loop should also be stretched before being put into the container. Once the required loop length has been established, it should be annotated on the reserve packing card for future reference.

### **4.1 Loop material**

Argus loops are made from Dyneema line and are specifically designed for use with the system. This is a thin material with a diameter of ~1.8mm and a breaking strain of approximately 180kp – 200kp.

**Only Argus or Cypres™ loop materials are permitted.**

The use of other materials could cause damage to the loop hole coating in the release unit and is NOT PERMITTED.

### **4.2 Argus Loops**

Standard and running loops must be impregnated with silicone on the first 2.5 to 4 cm. NOTE: As a general rule, the eye of any reserve loop should be as small as practicable to prevent the possibility of reserve canopy material becoming trapped. The diameter of a normal pencil or cigarette is ideal. The entire reserve loop should be impregnated with silicone except for 1cm above the disc, after installing the loop into the disc. This increases flexibility and helps to ensure a fast reserve opening. It also ensures that during manual opening of the reserve the loop will slip through the loop hole of the release unit freely, and it reduces the required pull force. When making your own loops, do not forget to impregnate them with silicone. This is simply done by rubbing the silicone into the loop material with finger and thumb, or by using a felt pad. The silicone must be acid-free.

- **Standard Loops for 1-pin and 2 Pin Container**  
Standard loops have to be replaced with each repack.
- **Running Loops**  
These loops must be replaced if there is any visual damage.
- **Quick Loops**  
Do not use silicon oil for Quick-loops.  
These loops must be replaced if there is any visual damage.
- **LOR-Loops**  
These loops must be replaced if there is any visual damage.

### **4.3 Loop washer**

The potential weak spot in a reserve closing loop is where it is threaded through the washer. Excessive tension can lead to the cord breaking at the knot, or becoming so compressed that the loop slips through the hole in the washer. To overcome this problem, we have developed a support disc with 2 slits and one hole. The loop material is tightly wound 2 times, and thus only requires a small knot. The two windings absorb a great deal of strain resulting in very little decrease in the breaking strength at this critical point. Alternatively, Cypres™ 'smileys' can also be used.

### **4.4 Tools to use**

When closing the reserve container the use of a straight pull on the pull up cord/closing loop is strongly recommended. The use of a mechanical advantage such as a T-bar or a twisting rod can impose unacceptable strain on the closing loop and weaken the loop to a point that it may break prematurely.

## 5. Maintenance of the Argus

The maintenance work for Argus has to be done by Aviacom or another authorized service center. The following Points 5.1, 5.2, and 5.3 could be done also by any certified Rigger.

### 5.1 Battery replacement

Before replacing batteries, please read the detailed information in the User's Guide section.

It is most important to remember that these batteries are sensitive to short circuits which will render them unusable. Please use—caution when handling the batteries or replacing them. A short circuit which lasts for just fractions of a second can render the batteries unserviceable.

The battery must be replaced after  
every year **or**  
500 jumps **or**  
if the low battery error code is encountered during self-test,  
whichever comes first.

This is done as follows:

Remove the closing screw from battery cover and remove the cover. Remove old batteries. Check the compartment for dirt, moisture or foreign objects, if necessary, clean thoroughly. Install new batteries, ensuring the correct polarity (+) or (-). Replace the cover by inserting the cover tab into the slot in the bottom of the box, and then push the cover closed. Insert the screw and tighten enough to compress the sealing ring. As soon as you close the cover, the display will show the Argus logo for a couple of seconds.

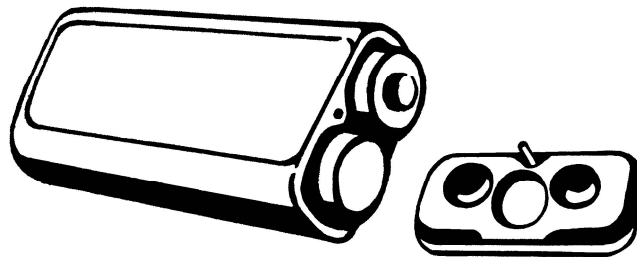

**Note: After each battery replacement, the internal clock (Hour, minute, day, month and year) has to be reset. See User manual for Details. The rigger should set the internal clock after each battery replacement.**



## 5.2 Water resistant filter replacement

The design of the Argus allows water jumps without removal of the unit. It is water resistant up to a water depth of 3 feet (1 meter) for durations up to 30 minutes. This is achieved through a sealed cutter, a sealed control unit, sealed connectors and a special filter. The filter allows precise measurement of the air pressure and at the same time prevents water from entering the unit. As long as there is no contact with water, the filter never needs to be replaced by the user. If water does contact the filter, it must be removed and a new filter installed.

**WARNING - THE FILTERS ARE FOR ONE TIME USE ONLY!  
USE ONLY ARGUS FILTERS THAT COME FROM A SEALED BAG.**

The Argus comes with one spare filter and a 'toothpick'. Filter replacement can be done by the owner (or rigger/packer if your local regulations do not allow you to do so.). After water contact, the rig and the reserve must be dried according to the manufacturers' instructions. After that, the rig and Argus (with the new filter) can be repacked and used again.

### **Filter Replacement:**

If there is water in the inside of the battery cover, thoroughly dry it with a soft cloth. Remove the old filter from cover by gently peeling the Gore-tex membrane away with the supplied toothpick or with the point of a pencil. Do not use this filter again. Check that the air holes are clear by holding it in front of a light. Insure the cover is dry before applying the new filter. Place the new filter, with the sticky side toward the holes in the battery cover, and apply a gentle pressure on all parts of the filter to create a good seal. Insert the batteries, close the cover, then reconfigure the clock and check the configuration parameters, including operating mode and units of measurement.



### 5.3 Replacement of the Cutter

Once Argus has fired, it is **not** necessary to return the Argus to Aviacom or another authorized service center for replacement of the release unit. The unit is equipped with an easy to replace cutter. Turn the screw of the cable connection, until the cable is easy to disconnect. The Argus uses a Nobel Metron pyrotechnic cutter with a cylindrical knife, designed solely for use with the Argus. The cutter is field replaceable. A replacement cutter is free upon presentation of the completed life saving report form.

To replace the cutter, first switch off the Argus. Unscrew the M8 (1/4") connector counter clock-wise and remove the old cutter. To install the new cutter, place the 3 pin female connector onto the three pin male connector on the box, and push it gently until it stops. Then, tighten the connector screw clockwise. Do not use excessive force.

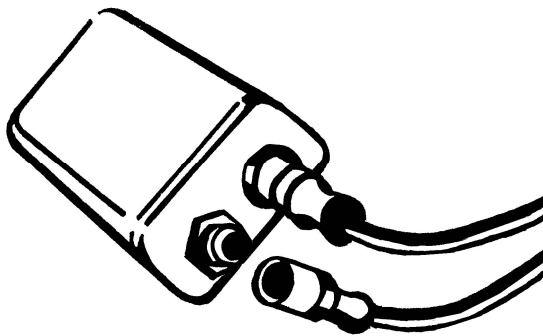

- Before installing a new cutter always check the connector for dirt or moisture. If there is anything abnormal, please contact your rigger, Argus distributor, or the manufacturer.

Argus Authorized Riggers can disconnect the cutter to attach a test probe, which can be purchased from Aviacom.



## 5.4 Software Update

Software updates for the Argus have to be done only by Aviacom, or service centers specifically authorized by Aviacom to perform this service.

## 6. Argus Scheduled Service

The Argus must be checked every 4 years after the date of first use (when the batteries are inserted for the first time). The maximum life span of the Argus is not limited, as long as the unit passes these tests. In order to keep your Argus available during your jumping season, there is a 7 month window for the scheduled service around the 4 year anniversary of the first use. Your AAD still can be serviced at any later date, but the time frame for the next Scheduled Service will remain on multiples of 4 years +/- 3 months, starting from the first use of the Argus.

The Argus is a technically very advanced and compact device, which, during the period between Scheduled Services, is often subject to diverse mechanical and environmental forces. These demanding influences may cause the need for parts replacements or even reprogramming, even if the equipment is used infrequently. The ARGUS works during each and every jump, even if it does not activate the cutter. A cutter activation is the end of a long sequence of computations. In order to guarantee that each unit functions as accurately as new equipment, it is necessary to perform a thorough functional check at the scheduled service interval. Daily wear and tear also affects electronic components. Over the years, chemical reactions can affect the electronic components and mechanical and thermal forces may have a substantial influence, as well. The Argus Scheduled Service examines these influences and provides the opportunity to correct the effects of this aging process. Aviacom and its partners see the Scheduled Service as more than just a functional check of the Argus AAD. We would like to be as certain as possible that the equipment can continue its work, error free, until the next Scheduled Service. This service also provides a regular opportunity to perform firmware updates, as they may become available. Scheduled Service is a precautionary measure, in order to assure the most important characteristic, the reliability of the Argus.

### 6.1 ARGUS Scheduled Service

Normally, we need 5 working days, in order to accomplish all necessary work. Sometimes, however, if parts need to be replaced, additional work may be necessary. Therefore the time for service may be extended. If the Argus passes the first visual inspection, the unit is tested with a probe in a pressure chamber for a series of "Fire"/"No Fire" functional tests. If parts are replaced or an upgrade is performed, the unit may be submitted to additional testing, in order to insure the correct functioning of the unit. Some tests take a couple of days and cannot be safely shortened.

### 6.2 Battery replacement - sticker

At each Scheduled Service, the batteries are replaced as well as the Gore-tex water resistant filter. Eventually, the sealing rings or the battery cover may need replacement. If a connector is damaged, the cutter or the remote control will be replaced. We recommend that you maintain a record of the last battery change by placing a sticker on the outside of the unit, displaying the month and year of the last battery change.



### **6.3 Warranty period**

Within our warranty period of 2 years from date of manufacture, defective parts are replaced free of charge. After the warranty period expires, the owner will have to pay for the replacement of the damaged parts. Replacement parts and repairs are not included in the price of the Scheduled Service.

### **6.4 ARGUS Scheduled Service**

Upon completion of the ARGUS Scheduled Service, a holographic seal is placed on the control unit. The label indicates the date of the last Scheduled Service.

### **6.5 Service Locations**

The service can be done by Aviacom itself at the factory, or at the designated service centers. These centers have been carefully selected, based on their customer care and high standards. These accredited service centers will download information from your Argus and send the data to Aviacom, so that we can analyze the performance of all units in the field. This ongoing data analysis will further ensure the reliability of all Argus AADs in use.

### **6.6 Cost of Scheduled Service**

The 4 year check will cost 95.00 € or US\$140.00. This cost includes the following:

- Check of the electronics, the cutter, and the program
- Visual inspection of the overall state of AAD, the seals, and the connectors
- Replacement of batteries and filter
- Functional testing Fire/No Fire with a test probe.
- Collection of data in the Argus
- Application of holographic control seal
- Test certification

## **7. Warnings**