

Thanks for choosing
Sun Path Products, Inc.



Home of the



*We're dedicated to making the
industries best harness/container.
EVERYTIME!*



4439 Skydive Lane Zephyrhills, FL 33540 USA

REVISION: 02- ISSUE: 01/ March 07



SERIAL # _____

CONTAINER SIZE _____

YOKE _____

HARNESS _____

LATERAL _____

LEGPAD _____

P.O. # _____



Sun Path Products, Inc.
4439 Skydive Lane Zephyrhills, FL
33540 USA
www.sunpath.com

Javelin Odyssey Sport Parachute Harness/Container Assembly Owners Manual

Table of Contents:

1. Warning	Page 4
2. Introduction	Page 5
3. Parts List	Page 6
4. Main Packing Instructions	Page 7-28
5. Kill Line Instructions	Page 12
6. Throw-Out Pilot chute Packing Instructions	Page 11
7. Skyhook Reserve Static line, Release cable, and Reserve Ripcord Installation	Page 29
8. Automatic Activation Device Installation	Page 39
9. Ram Air Reserve Packing Instructions (with Skyhook) (<u>with out Skyhook</u>)	Pages 45-67 Pages 68-73
10. 3 Ring Release/Main riser attachment	Pages 74
11. Before Using the Javelin	Page 78
12. Donning the Javelin	Page 79
13. Main Deployment	Page 80
14. Reserve Deployment (Partial Malfunction) (Total Malfunction)	Page 80 Page 81
15. Coloring Templates	Page 82
16. Maintenance Guidelines (Appendix A)	Pages 83

The purpose of this manual is to acquaint the rigger and prospective users with the functions, packing procedures and other features of the **JAVELIN/JAVELIN ODYSSEY** harness/container system. It is NOT intended to be a course in parachute jumping. This manual should be read and understood by anyone who intends to use a **JAVELIN/JAVELIN ODYSSEY** system for sport parachuting, however, it is the responsibility of the owner to be sure that the **JAVELIN/JAVELIN ODYSSEY** is correctly assembled, packed, maintained and used. It is also the jumpers own responsibility to assure that he/she is qualified for participation in sport parachuting activities. (Any gender references automatically refers to the user)

For more information on the **JAVELIN/JAVELIN ODYSSEY** harness/container system and general information about Sun Path Products, Inc. please check out our website <http://www.sunpath.com>

!!!!WARNING!!!!

Parachuting is a hazardous activity and there are dangers that which sometimes cannot be foreseen. No one should attempt to make a parachute jump unless they have been thoroughly trained by an experienced and qualified instructor. There are no guarantees that any equipment will function as intended, regardless of how it is assembled, packed maintained or used. Serious injury or death can result from the use, misuse, or attempted use of any parachute equipment.

!!! THE USER ASSUMES ALL RISK !!!

INTRODUCTION

The **JAVELIN/JAVELIN ODYSSEY** is a sport parachute harness/container system featuring back mounted main and reserve canopy containers. The reserve container is characterized by the partially exposed top plate of the reserve pilot chute, which is packed on the top of the side flaps.

The **JAVELIN/JAVELIN ODYSSEY** is equipped with the 3-Ring release system. Other standard features include throw-out hand deployed main pilot chute, single-pin reserve closure, step-in leg straps, and “wrap around” harness construction. This type of harness construction produces junctions which are not limited to the strength of the stitches. In the **JAVELIN/JAVELIN ODYSSEY**, the harness junctions are stronger than the webbing itself.

The reserve container will accept a ram-air reserve canopy. For ram-air reserves, the **JAVELIN/JAVELIN ODYSSEY** is supplied with a unique “MOLAR BAG”, a free bag which features zero thickness where the closing loop passes through it, eliminating the need for any preliminary fid or preliminary pull-up cord when packing the canopy into it. This also prevents any of the canopy fabric from coming into contact with the closing loop.

Design and testing of the **JAVELIN/JAVELIN ODYSSEY** was accomplished over a period of eighteen months and has resulted in one of the most “RIGGER FRIENDLY”

systems on the market. There is no additional sewing or tacking required to assemble the **JAVELIN/JAVELIN ODYSSEY**. An FAA certified senior or master parachute rigger or foreign equivalent with current skills should be able to assemble and pack this system by following the instructions in this manual.

The Javelin harness/container system was tested in accordance with AS-8015A and is approved by the FAA under TSO C23c, Category B.

In October 2001 the **JAVELIN/JAVELIN ODYSSEY** was retested in accordance with AS-8015 Rev. B and is approved under TSO C23d:

Max Operating Exit Weight of :		300 lbs (136 kg)
	<i>and</i>	
Max Operating Speed of:		170 knots (198 mph)
	<i>with</i>	
Average Test Peak Forces Measured:		7628.5 lbs.

PARTS LIST

The *JAVELIN/JAVELIN ODYSSEY* is shipped to the customer with the following components:

HARNESS/CONTAINER
MAIN RISERS WITH CONTROL TOGGLES
MAIN DEPLOYMENT BAG
* RELEASE HANDLE (CUT AWAY HANDLE)
MAIN PILOT CHUTE AND BRIDLE
RESERVE PILOT CHUTE WITH:
** BRIDLE AND “MOLAR” FREE-BAG
*** RESERVE RIPCORD WITH MARINE EYE
RESERVE STATIC LINE (RSL)/COLLINS LANYARD
RESERVE PIN AND LANYARD
(SKYHOOK LANYARD, OPTIONAL)
RESERVE CONTROL TOGGLES
MAIN CLOSING LOOP
RESERVE CLOSING LOOP
ONE EXTRA CLOSING LOOP (MAIN)
RUBBER BANDS
RESERVE PACKING DATA CARD
JAVELIN OWNERS MANUAL CD OR HARDCOPY

- * Only the *JAVELIN/JAVELIN ODYSSEY* reserve pilot chute may be used with the *JAVELIN/JAVELIN ODYSSEY* harness/container system. Do not substitute any other pilot chute.
- ** Only the “molar” free-bag may be used when packing the reserve canopy into the *JAVELIN/JAVELIN ODYSSEY* harness/container system.
- *** Only *JAVELIN/JAVELIN ODYSSEY* reserve ripcords are to be used.
- All *JAVELIN/JAVELIN ODYSSEY* are manufactured to accept most modern A.A.D. systems.

All components listed above are also available individually from:

Sun Path Products, Inc.
4439 Skydive Lane
Zephyrhills, Florida 33542 USA
(813)782-9242

Info@sunpath.com

Parts@sunpath.com

Rigging@sunpath.com

Main Packing Instructions

This chapter deals with the procedures for packing a ram-air main canopy into the *JAVELIN/JAVELIN ODYSSEY* harness/container system. Assembly and packing of the main must be done by an appropriately rated parachute rigger, under the direct supervision of a certificated parachute rigger or by the person making the next jump.

1. Carefully inspect the main canopy, suspension lines, control lines, slider and grommets, connector links or soft links etc., before assembling it with the risers. Replace or repair any worn or damaged parts. Also inspect the deployment bag, bridle and pilot chute.

2. Attach the main canopy to the main risers, being sure that the canopy is facing the same direction as the harness/container system and that each suspension line is clear from its attachment point all the way through the slider grommet to the connector link without passing around any other line. Be sure the control lines are clear from the trailing edge of the canopy to the control toggles. Each control toggle must be securely tied or larks headed to its control line at the location specified by the canopy manufacturer. Also be sure that the connector links are tight enough so that they cannot be loosened with the fingers alone. (finger tight + 1/4 turn). Also refer to the canopy manufacturers owners manual.

SPORT JAVELIN ODYSSEY Main Packing

Main Packing Instructions:

This chapter deals with procedures for packing the ram air main canopy into the Javelin/Javelin Odyssey Harness/Container system.

Reference the Main canopy manufacturer instructions for complete and specific information regarding attachment of main canopy to main risers, setting of brakes and packing of the main parachute.

Set the deployment brakes by pulling the cat's eye through the guide ring and securing with the stiffened portion of the top of the toggle.



Fig. MP1

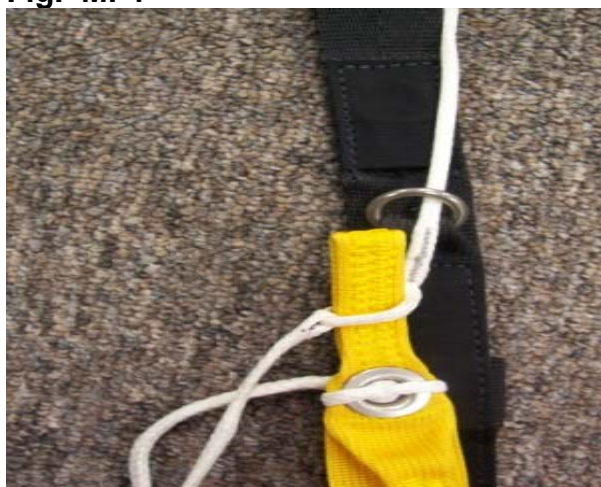

Fig . MP2

SPORT JAVELIN ODYSSEY Main Packing

Set the top of the toggle into the Type 3 keeper, with the brake to toggle excess loop towards the outboard side, and brake line to the inboard as shown.

Fig. MP3



Fig. MP3

Set the bottom portion of the toggle into the bottom keeper.



Fig. MP4

SPORT JAVELIN ODYSSEY Main Packing

“S” fold the Brake to toggle excess and stow it in the elastic keeper on the back side of each main riser.



Fig. MP5

Completed Brakes Stowed should look as shown.

Inboard



Outboard



Fig. MP6

Bridle and Deployment Bag attachment to main canopy.

Attach main deployment bag to bridle attachment point on top center cell.

NOTE: For bridles that are sewn to the inside of the main D bag, skip to Fig. MP9



Fig. MP7

SPORT JAVELIN ODYSSEY Main Packing

Be sure that the rapide link at the base of the bridle is secure and the Hex Head portion is concealed inside the type 3/Cotton loops. Ensure that the center/kill line is routed through the center of the 2 cotton buffer loops.

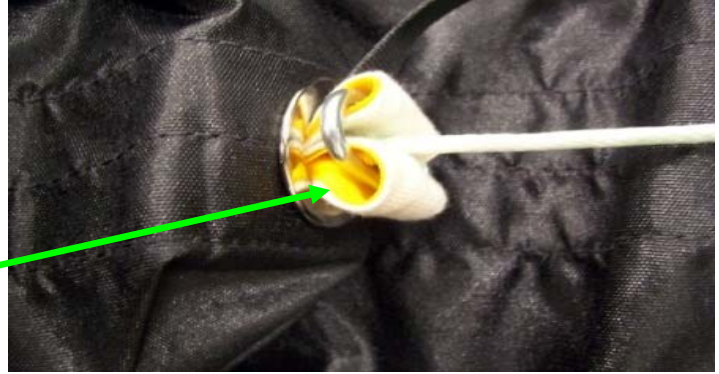

Fig. MP 8

Fig. MP9
Attach Rapide link to bridle attachment point on top center of main canopy.



Fig. MP9

Fasten one or both Rapide links (if applicable) with an adjustable wrench. (finger tight plus a ¼ turn)



FIG. MP10

SPORT JAVELIN ODYSSEY Main Packing

Kill Line instructions:

The pilot chute should be “cocked” before placing the deployment bag. To do this, simply anchor the bag (you foot works great) and pull out on the pilot chute handle until the centerline is tight.

Fig. MP11



To double check that you have fully cocked the pilot chute, check to see that the green portion of the kill-line is visible in the window on the bridle.

Fig. MP12

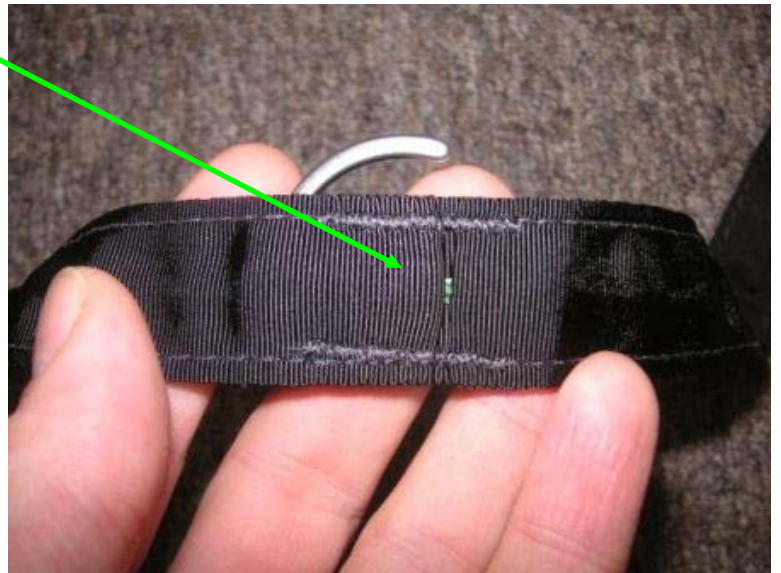

SPORT JAVELIN ODYSSEY Main Packing

**Follow the main canopy
manufactures instructions for
packing of the main canopy.**



Fig. MP13

Once the main canopy is in long fold. It is time to "S" fold the canopy and place the main deployment bag onto the canopy.



Fig. MP14

SPORT JAVELIN ODYSSEY Main Packing

Begin with the first canopy "S" fold.



Fig. MP15

Make the first "S" fold approx. 15-20cm wide, with slider grommets in the center.



Fig. MP16

SPORT JAVELIN ODYSSEY Main Packing

Control the main canopy with knees and make second canopy "S" fold.



Fig. MP17

Control entire "S" folded main canopy with body weight and knees prior to inserting into the main deployment bag.



Fig. MP18

Place entire main canopy into main deployment bag with suspension lines centered. Try to fill the corners and sides of the bag to distribute the bulk evenly and avoid forming a lump in the middle.



Fig. MP19

Mate the locking stows with the suspension lines to close the mouth of the main deployment bag.

SPORT JAVELIN ODYSSEY Main Packing

Center Locking Stow, to be stowed first.

During this part of the packing procedure always make sure that the rubber bands used for the locking stows are strong and in good condition. The weight of the canopy inside the bag comes to bear on these locking stows when the canopy is lifted off the jumper's back during deployment and broken locking stows at this point may result in an out-of-sequence deployment or line dump.

Second mouth lock stow

3rd, final mouth locking stow.



Fig. MP20



Fig. MP21



Fig. MP22

SPORT JAVELIN ODYSSEY Main Packing

Continue stowing the remaining main suspension lines across the bottom of the bag in the rubber bands at each end. Make line stows as per canopy manufacturers recommended size/length. Leave 300mm-400mm of lines unstowed between the bag and connector links. (Slinks)

Place the bag (lines down) on the outside of the bottom of the container.



Fig. MP23



Fig. MP24

SPORT JAVELIN ODYSSEY Main Packing

IMPORTANT NOTE:

Place main risers **ON TOP of the riser cover pockets and outer yoke.**

Placing the main risers under the yoke can cause delayed release of riser covers.



Fig. MP25

Place Main Risers on top of outer yoke and route main risers in the “trough” between the reserve container and riser covers.



Fig. MP26

SPORT JAVELIN ODYSSEY Main Packing

Close riser covers and secure with tuck tabs as shown.



Fig. MP27

Open the main container and prepare to place the main canopy inside.

Place a pull-up cord through the main closing loop and clear it from all suspension lines.

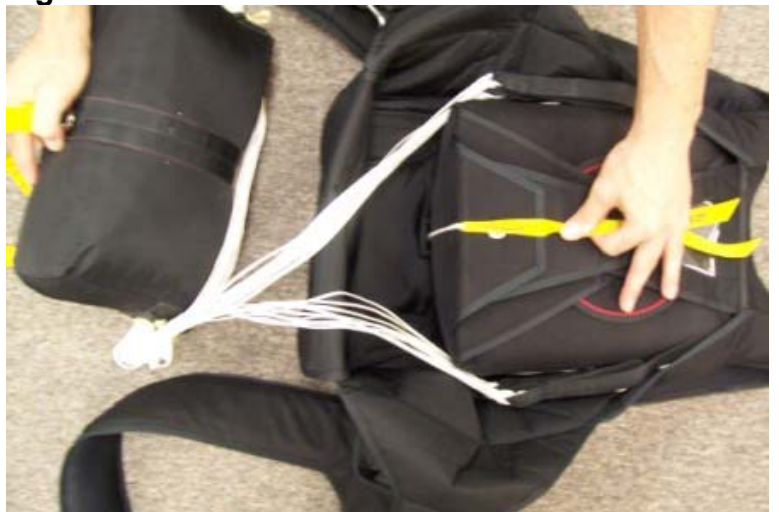

Fig. MP28

SPORT JAVELIN ODYSSEY Main Packing

Place the main deployment bag into the main container. Rotate the bag so that the grommet on the center of the bag is facing directly up towards the bottom of the reserve container. Seat the deployment bag as far into main container as possible. Ensure that bottom corners are filled.

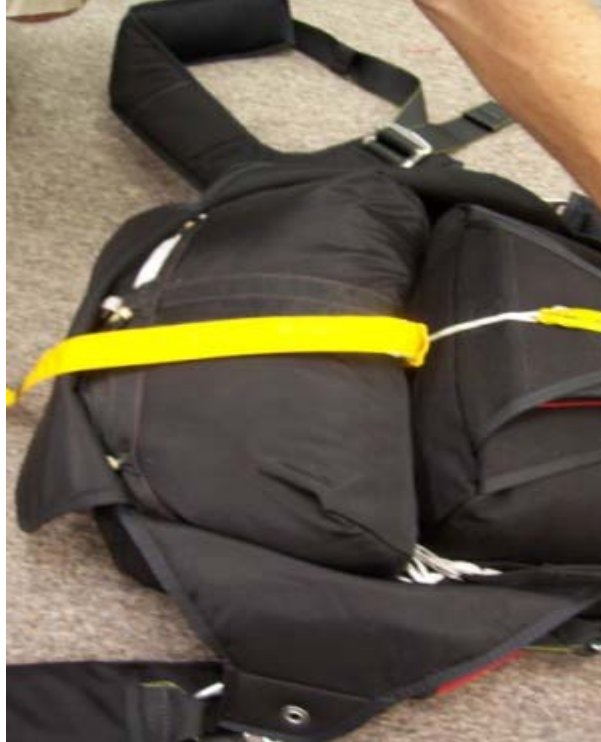

Fig. MP29

Route the bridle so that the running end is to the right.



Fig. MP30

SPORT JAVELIN ODYSSEY Main Packing

Close the bottom flap,

Helpful Hint: attempt to get the bottom flap as far up towards the bottom of the reserve container as possible.



Fig. MP31

Close the top flap, keeping the
bridle to the right.



Fig. MP32

**SPORT JAVELIN ODYSSEY
Main Packing**

Mate the Velcro on the bridle just above the curved pin, to the Velcro on the top flap.

Close the Top flap.



Fig. MP33



Fig. MP34

Close wearers' left side flap

**SPORT JAVELIN ODYSSEY
Main Packing**



Close wearers' right side flap.

Fig. MP35



Fig. MP36

SPORT JAVELIN ODYSSEY Main Packing

Secure main container closure with the curved pin. Pin should be orientated upwards, allowing the running end to the PC to run down.

Carefully remove the pull up cord.



Fig. MP37

Route running end of main kill line
bridle under the wearers right side
flap and continue under the bridle
cover. Stow the length of bridle in
the bridle cover all the way to the
BOC (bottom of container) pocket.



Fig. MP37

Lay the main pilot chute out flat with

SPORT JAVELIN ODYSSEY Main Packing

the mesh side up. The bridle should be running out at the 6 'o clock position.



Fig. MP38

Fold the pilot chute in half.



Fig. MP39

And in half again



Fig. MP40

SPORT JAVELIN ODYSSEY Main Packing

“S” fold the bridle and stack on top of pilot chute.



Fig. MP41

Fold the sides inward, just past half way, on top of the “S” folded bridle.



Fig. MP42



Fig. MP43

SPORT JAVELIN ODYSSEY Main Packing

Fold the sides inward again towards the center and roll into a cylindrical shape, keeping the pilot chute and bridle as neat and clean as possible. (the tighter the better)



Fig. MP44



Fig. MP45

Fold remaining bridle outside of the folded pilot chute.



Fig. MP46

Place the folded pilot chute into the

SPORT JAVELIN ODYSSEY Main Packing

BOC pocket.

NOTE: Ensure that the P/C bulk is evenly distributed inside the full length of the BOC pocket. This will aid in ease of deployment and reduce hard pull scenarios.



Fig. MP47

Close the main pin cover



Fig. MP25

Skyhook Reserve Static Line/Collins Lanyard, Release Cable and Reserve Ripcord Installation:

This system has been equipped with the Skyhook. The Skyhook RSL/ Collins Lanyard and Release cables are critical parts of this system and must be installed properly for the skyhook to function as designed.

Ensure that the Skyhook RSL/Collins Lanyard and Release cables are installed as per published instructions in this manual.

Half hitch or “larks head” both lanyards onto the RSL/Collins lanyard in a uniform fashion.

First open the RSL channel so that the bound edge is exposed.

Fig. RSL 2



Fig. RSL 1



Fig. RSL 2

Open the channel up so that the under side is exposed.

Fig. RSL 3



Fig. RSL 3

Place the Skyhook RSL/Collins Lanyard onto the under side of the channel. Align the looped end of the RSL with the release housing "split".

Fig. RSL 4

Fold over lower end (snap shackle end) so that the excess is kept in the folded channel and orientate so that the snap shackle is easily mated to the RSL ring on the right main riser.



Fig. RSL 4

Fold Type 4 RSL back

Fold the first portion of the RSL channel over with the RSL inside.
Fig. RSL 5



Fig. RSL 5

Fold 2nd portion over to completely hold the RSL in place. Ensure that the looped end is still aligned with the release housing split.

You should have approximately 80mm (3 3/8") of RSL from the exit point of the lower RSL channel to the snap shackle.

Fig. RSL 6

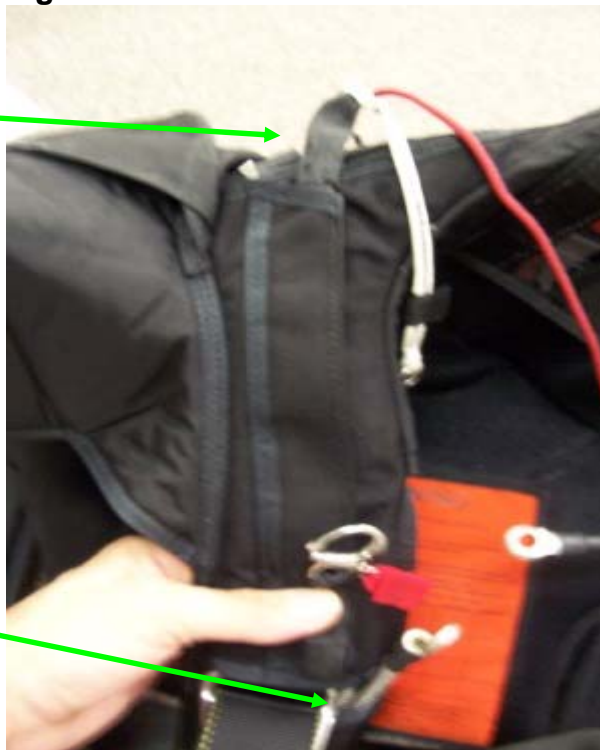

Fig. RSL 6

Insert the Release cables into the release housings and seat the release handle into the pocket.

Fig. RSL 7-8



Fig. RSL 7

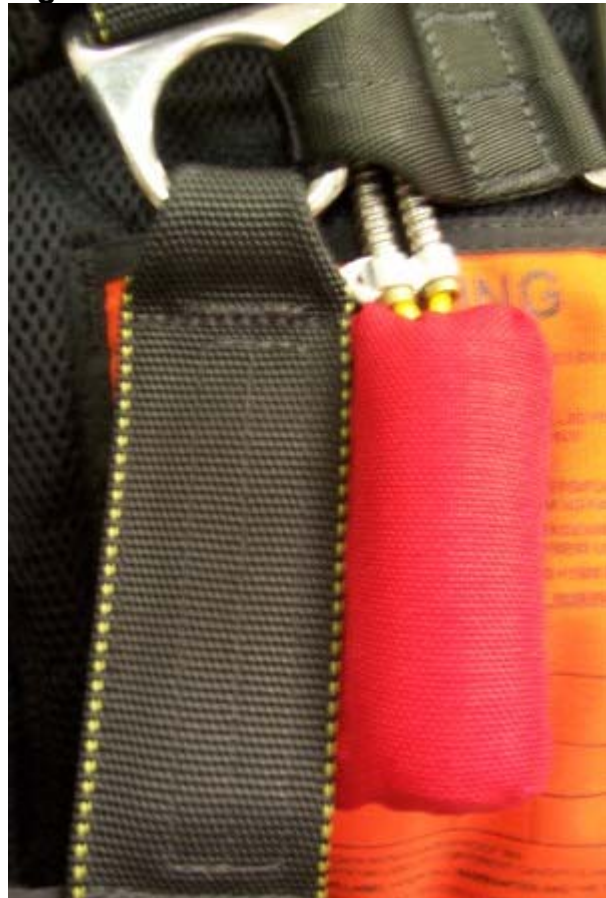

Fig. RSL 8

The long side release cable will exit the first split release housing on wearers' right side at the top of the reserve container. **Fig. RSL 9**



Fig. RSL 9

Thread release cable through the looped end of the Skyhook RSL/Collins Lanyard ONLY. (JR007-SH) **Fig. RSL 9**

NOTE: Be sure that the release cable is free and clear of Cypres Control unit cable, Control toggles and all other system parts prior to inserting into second housing.



Fig. RSL 10

Continue threading the release cable into the second housing, exiting on wearers left side. **Fig. RSL 10**

NOTE: The NON RSL side (wearers left) should activate before the RSL side (wearers right). This is done to ensure that the Non-RSL side main riser is released, free and clear **BEFORE** the RSL side is activated.

Measure and cut release cable excess.

Non RSL Side, Wearers LEFT should measure **140mm (+/-5mm) (5.5" +/- 1/4")**.

Fig. RSL 11



Fig. RSL 11

RSL Side, Wearers RIGHT should measure **153mm (+/-5mm) (6" +/- 1/4")**. **Fig. RSL 12**

Cut to appropriate length and melt ends of Lolon coating with a lighter in order to completely cover the cut cable end. Smooth over so that there are no snag points or rough ends.

Continue attaching Main risers as per instructions on page 65-68.



Fig. RSL 12

Reserve Ripcord, Ripcord pin lanyard and skyhook red lanyard installation.

Mate the Velcro from the Pin flap and Ripcord Lanyard so that the hook Velcro is completely covered by the pile Velcro as shown here.



Fig. RSL 13

Ensure that the 2 lanyards (Red and White) are properly orientated. The Red Lanyard should be towards the left and the White 1000lb spectra Ripcord lanyard to the right when larks headed onto the Skyhook RSL/Collins lanyard.
Fig. RSL 14

Be sure that these 2 lanyards **DO NOT** cross each other when the rig is packed for use.



Fig. RSL 14

Insert the Marine eye end of the Reserve Ripcord into the Reserve ripcord housing on the wearers' left side harness. **Fig. RSL 15**

This will exit at the top of the reserve container on the pin flap.

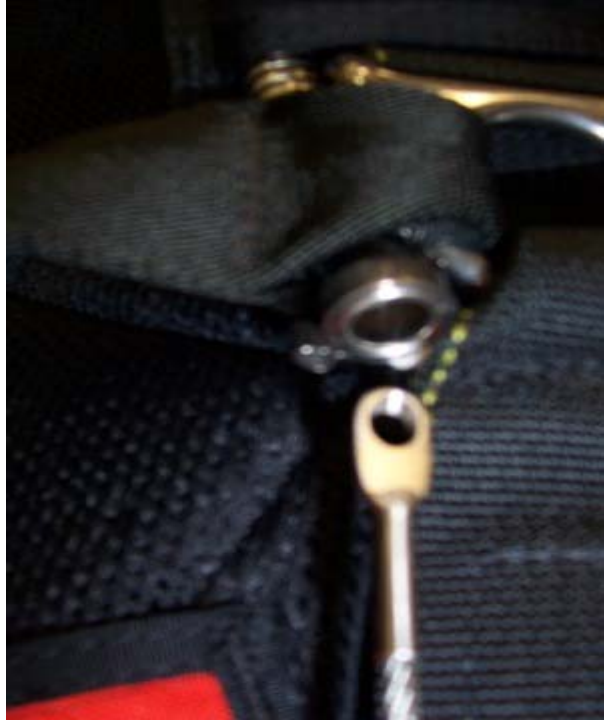

Fig. RSL 15

Route the Reserve ripcord cable through the guide ring.
Fig. RSL 16



Fig. RSL 16

Seat the reserve ripcord handle into the reserve pocket and mate the Velcro closure inside the pocket.

NOTE: For soft ripcord handles, pads or Phat Daddy handles, be sure to cover the unused hook Velcro on the inside of the pocket to avoid damage.

NOTE: The Velcro keeper on the inside of the reserve pocket is purposely NOT sewn down completely to the harness. This is to allow for freedom of movement within the harness without dislodging the reserve ripcord handle.



Pass the end of the reserve pin through the marine eye on the end of the reserve ripcord cable as shown. **Fig. RSL 18**

Ensure the 45 degree cut is towards the pin.

Be sure NOT to damage the pin in any way with the sharp inside edge of the Marine eye.



Fig. RSL 18

Prior to packing:

Install:

1. Skyhook RSL/Collins Lanyard
2. Ripcord Pin with Lanyard
3. Reserve Ripcord
4. Release cables and handle



Fig. RSL 19

Automatic Activation Device Installation:

This system has been equipped with a pocket and sleeve system to allow for an AAD to be installed. Compatibility with the Javelin harness/Container system does not certify the AAD unit in any way.



Fig. AAD 1

Consult the AAD manufacturer's instructions for proper orientation of the unit within the pockets and H/C system.

.

Place the main AAD unit into the pocket according to AAD manufacturer's instructions.

Fig. AAD 1



Fig. AAD 2

Route the control unit through the Type 3 sleeve inside bottom of the reserve container.

Fig. AAD 3

Pull the control unit complete through the first Type 3 sleeve and pull the slack out of the cable.



Fig. AAD 3

Place the control unit into the “slot” cut into the top center of the reserve container and back pad.

Fig. AAD 4



Fig. AAD 4

Seat the control unit so that the LCD display and Red button are clearly visible through the clear window on the back pad.

Fig. AAD 5



Fig. AAD 5

Fold back the excess control unit cable into a single "S" fold and stow inside the top of the first Type 3 channel.

Pull the loop back towards the bottom of the reserve container and dress neatly within the sleeve.

Fig. AAD 6

NOTE: alternate methods of coiling the cables and stowing into the Cypres pocket are also authorized, but not illustrated.



Fig. AAD 6

Ensure that there is a minimum amount of slack between the first and second Type 3 sleeves.



Fig. AAD 7

Route the cutter through first Type 3 sleeve.

Fig. AAD 8



Fig. AAD 8

Exit half way up on the inboard side. **Fig. AAD 9**

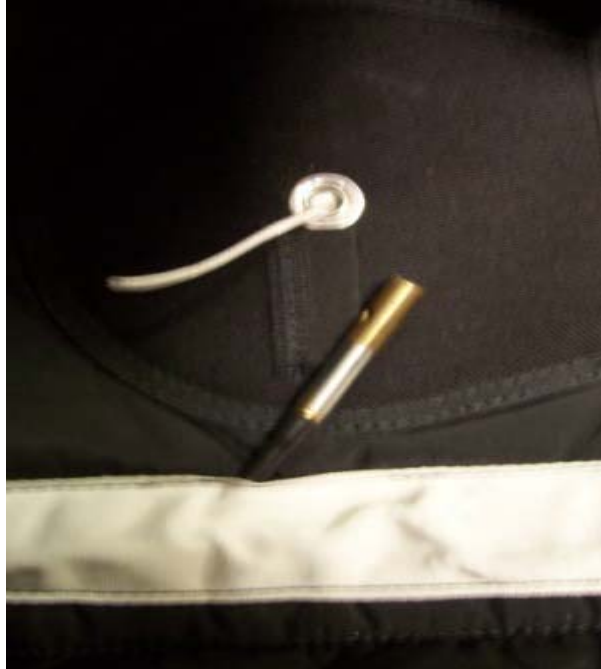

Fig. AAD 9

Place the cutter through the elastic keeper on floor plate and route closing loop through cutter. **Fig. AAD 10**



Fig. AAD 10

Carefully pull the cutter cable slack back through the sleeve and coil. Ensure that there are no kinks or sharp bends in the cutter cable when stowing.



Fig. AAD 11

Close the Velcro closure to keep cable coil excess in place.



Fig. AAD 12

SPORT JAVELIN RESERVE PACKING

Reserve Packing

Helpful Hint: Before starting the pack job, copy the type of canopy, serial numbers and date of manufacture from AAD unit as well as both main and reserve canopies into an appropriate log book.

Make a thorough inspection of all components of the reserve parachute - Reserve Pilot Chute, Reserve Bridle, Free bag, Reserve Canopy, lines, slider, slinks, and harness/container system.

Required Tools:

1. Adjustable Wrench
2. Temporary Pin with flag
3. Pull up cord, Cypres pull up cord or 1000lb spectra.
(recommended)
4. Wooden Packing paddle
5. .22 caliber rifle cleaning rod.
6. (2) 125mm (5") strips of Velcro loop with flags
7. Fine tip permanent marker.
8. Scissors
9. Finger trapping tool.
10. Seal Thread
11. Seal press
12. Closing device
13. Steel ruler



Fig. 1



Fig. 2

SPORT JAVELIN RESERVE PACKING

Inspect and assemble the reserve canopy in accordance with the manufacturers instructions.

Setting Reserve Deployment brakes

With the top of the toggle routed through the cat's eye of the steering line, secure top and bottom portions of toggle in keepers, with excess brake line towards the outboard side.

Fig. 4.



Fig. 3



Fig. 4

**SPORT JAVELIN
RESERVE PACKING**

Stow excess steering line through both elastic keepers.

Fig. 5



Fig. 5

Bring half of the excess steering line back up through both keepers. Dress excess to be neat and clean as shown in Fig. 6.



Fig. 6

SPORT JAVELIN RESERVE PACKING

Follow the manufacturers reserve packing instructions for “Pro Pack” method.

Sun Path Products highly recommends the “PRO PACK” method for all ram-air reserves packed into Javelin and Javelin Odyssey Harness/Container systems.

The canopy should look similar to Fig. 7, after it has been flaked and folded.



Fig. 7

Flake the center rear of the tail out, and wrap around folded reserve canopy.



Fig. 8

**SPORT JAVELIN
RESERVE PACKING**

Ensure to leave the nose sections
exposed to the front.



Fig. 9



Fig. 10

**SPORT JAVELIN
RESERVE PACKING**

Fold back the bottom portion of the tail, and make the first canopy "S" fold.

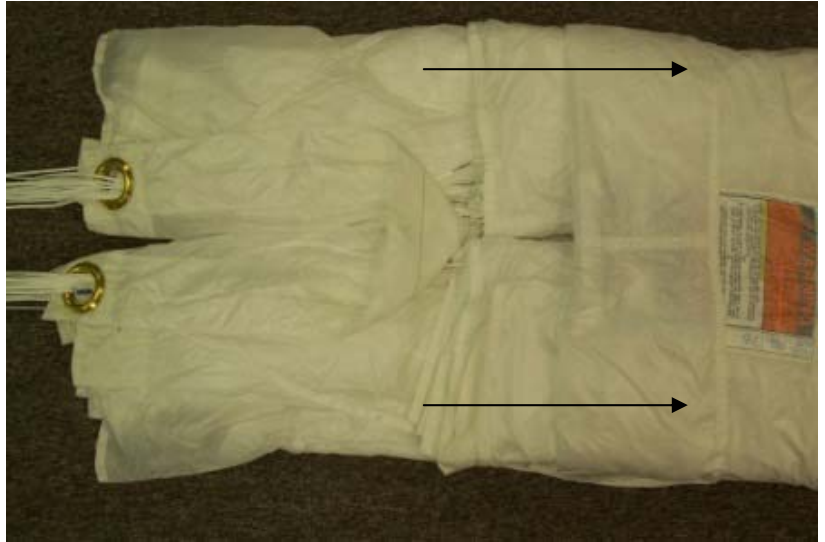

Fig. 11



Fig. 12

Place slider grommets so that they are to the outboard of center.



Fig. 13

SPORT JAVELIN RESERVE PACKING

Re dress the center of the tail to cover the first “S” fold. Attempt to make the canopy as wide, or just wider than the free bag.

NOTE: Do not use any other deployment bag. Only the appropriate size Javelin/ Javelin Odyssey “molar” bag may be used in the Javelin or Javelin Odyssey harness/container system.



Fig. 14

At this point it is necessary to spread the top of the canopy into halves by pushing down into the center from the top and spreading it outward into a “V” shape.

To keep the canopy symmetrically divided, use the seam on the top of the center cell as a reference. Split the canopy by accordion folding the center cell.

This will separate the canopy into 2 even halves, evenly split side to side.

Ensure that the leading edge of the center cell is exposed.



Fig. 15

SPORT JAVELIN RESERVE PACKING

Gather and dress each "ear" neatly. Ensure that the bulk of each side is distributed evenly.

Make the LEFT side "S" fold and hold in place with your left knee.

Note: the width of the second "S" folds are approximately the same as the first.



Fig. 16

Make Right side "S" fold and hold in place with Right knee.



Fig. 17



Fig. 18

**SPORT JAVELIN
RESERVE PACKING**

Once the 2nd "S" folds are made, carefully fold the extended portion of the ears UNDER so that the top of the ears are under the first 2 "S" folds. This will aid in filling the free bag and container properly.

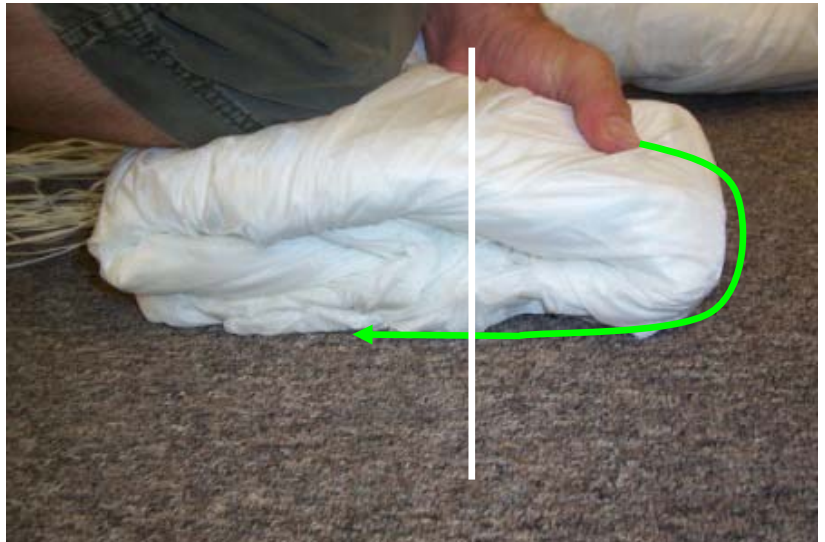

Fig. 19



Fig. 20

While keeping control of the pack job, place the ears into the top of the free bag.

Place main bulk of canopy into the remainder of the free bag, keeping the canopy in 2 separate halves as much as possible.



Fig. 21

SPORT JAVELIN RESERVE PACKING

Prior to closing the mouth lock on the free bag, carefully open the folds as to expose the slider grommets. Gently place the slider grommets to the outside of center. This will allow for a deep “valley” in the pack job allowing room for the AAD and reserve pilot chute fabric when closing the reserve container. Fig. 22

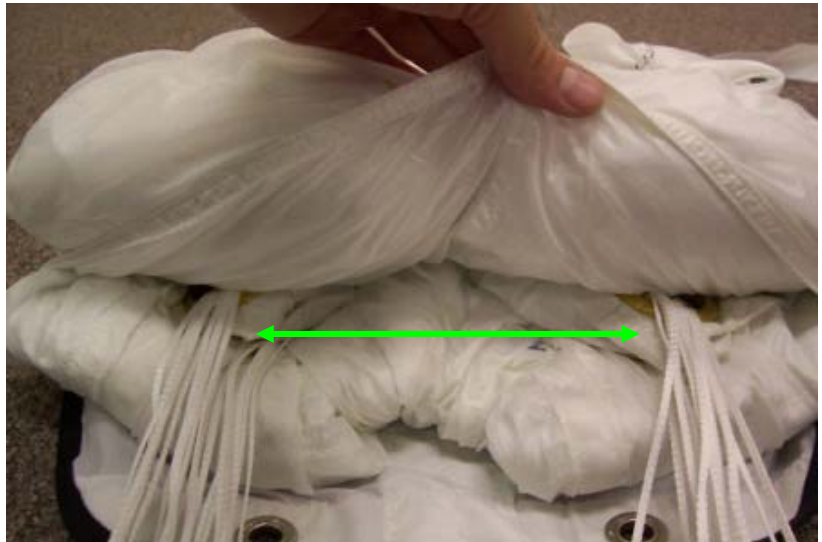

Fig. 22

Lock the mouth of the free bag by making two stows with the suspension lines in the “Safety Stow”. (This is the loop made of 1/8” shock cord). Fig. 23



Fig. 23

NOTE: Javelin/ Javelin Odyssey safety stows must be used – use of any other may void TSO.

Helpful Hint: Use loop Velcro strips with flags to cover any expose hook Velcro while stowing the suspension lines.

Stow remaining lines in the line-stow pouch on the back of the free bag. Make Figure of 8 stows with the lines, the width of the pouch. To close the pouch, remove the Velcro strips and mate the Velcro at the mouth of the pouch, being sure that none of the suspension lines are captured by the closure.



Fig. 24

SPORT JAVELIN RESERVE PACKING

NOTE: Leave approx. 100mm-150mm (4-6") of excess line out of the line stow pouch to the top of reserve risers.

After all lines are stowed, take time to mold the pack job. Form the pack job into the basic wedge shape of the reserve container.

Kneel on the center of the free bag with knee. Gently work the pack job so that the bulk of material is worked to the outer sides of the free bag, creating a "valley" in the middle.

The bulk should be evenly distributed on either side of the pack job, leaving a "valley" in the middle. Fig. 26

Reminder: Ensure that the AAD unit is properly installed and closing loop is proper length and routed properly through the cutter.

Reference: Javelin/Javelin Odyssey AAD installation Pg 14-19 in this manual.

Reserve Closing Loop:
Helpful Hint: Suggested reserve closing loop after setting and pre stretching to be 54mm to 57mm. (2 1/8" +/-1/4")



Fig. 25

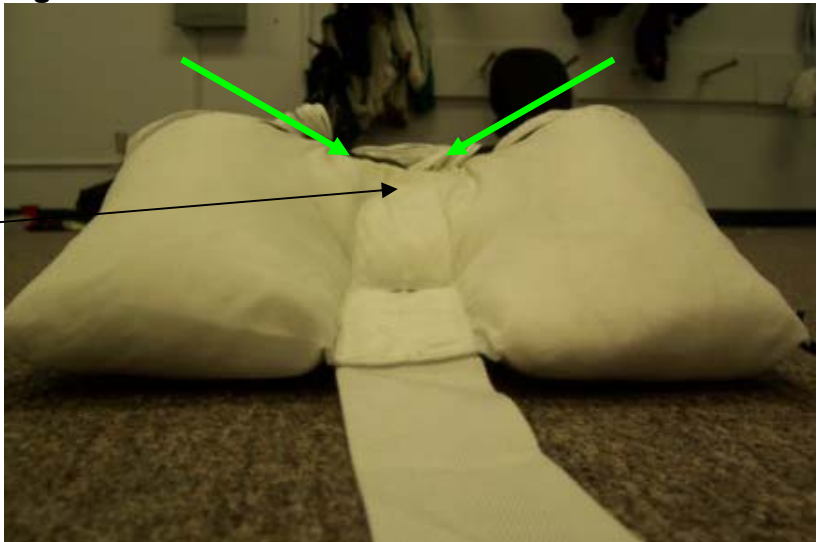

Fig. 26

SPORT JAVELIN RESERVE PACKING

Rotate the free bag over so the line stow pocket is up and lay the reserve risers in the container so that the connector links (slinks) are offset and laying flat inside the container. Fig. 27

Reserve Closing Loop:

Helpful Hint: *Suggested reserve closing loop after setting and pre stretching to be 54mm to 57mm. (2 1/8" +/-1/4")*

Pass the pull-up cord through the closing loop.



Fig. 27

Rotate the free bag over so that line stow pouch is facing down and thread the pull-up cord through the grommet in center of the free bag.

Center the free bag grommet with the AAD cutter and floor plate grommet. Kneel on center grommet and work the bottom portion of the free bag into the bottom corners of the reserve container. Ensure that the suspension lines are clear and free and risers are placed neatly and offset.

NOTE: For instructions on packing the Javelin Odyssey without the skyhook, reference pages 59-64



Fig. 28

SPORT JAVELIN RESERVE PACKING

Fold the bridle on top of the free bag up to the skyhook.

Split the fold into a "V" with 2 folds on each side of the closing loop with the skyhook on the wearers Left side as shown in Fig. 29. →



Fig. 29

Close the skyhook sub flap over the free bag and "V" folds. Pin in place. Ensure to get as much of the canopy bulk OUT, from under the skyhook sub flap and towards the outboard top corners of the reserve container.

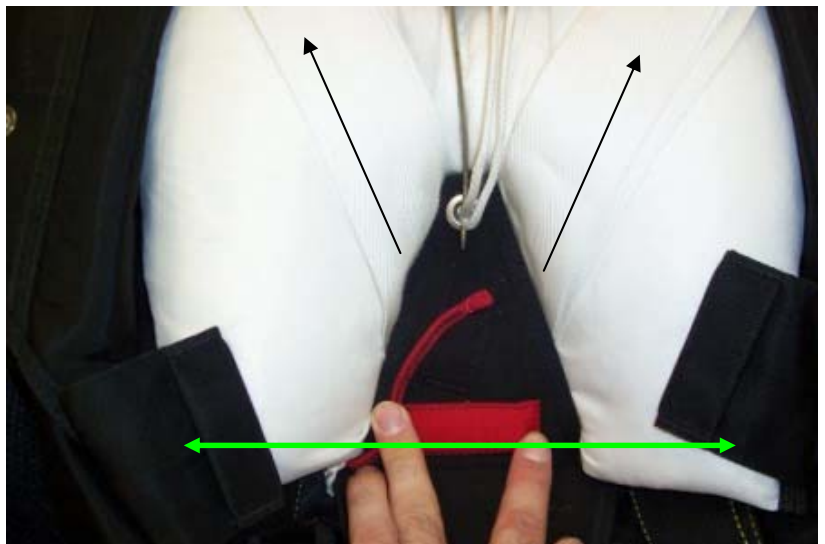

Fig. 30

SPORT JAVELIN RESERVE PACKING

Place approx 3-3.5" fold back of the red skyhook lanyard inside stowage pocket. (Red 1" Type 3 tape) Leaving 2-2.5" to the looped end of the red skyhook lanyard outside the pocket. **Fig. 31**



Fig. 31

Set the securing loop (Green Loop) from the rear of bridle into securing pocket (Black or Green 1" Type 3 tape) on the skyhook sub flap. This is to hold the skyhook in place. **Fig. 32**



Fig. 32

Allow the bridle to run out of the top of the container.

Tri fold the bridle behind the skyhook making the reserve bridle approx 1" in width. As shown here in **Fig. 33**



Fig. 33

SPORT JAVELIN RESERVE PACKING

Secure the loop end of the **red skyhook lanyard** onto the skyhook by running the lanyard **OVER TOP** of the bridle and onto the skyhook.

Safety tie the **red skyhook lanyard** in place with 1 turn seal thread, (**4-6lb tensile strength MAX**) through the holes in both top and bottom Lexan covers.

Secure the safety tie with a surgeons knot, locking knot.



Fig. 34



Fig. 35

**SPORT JAVELIN
RESERVE PACKING**

Using a wooden packing paddle, buffer the bridle folds from the side closing flaps. **Fig. 36**



Fig. 36

First close the wearer's left, side flap. Use the packing paddle to keep the bridle folds clear and from folding under the left side flap. **Fig. 37**



Fig. 37

SPORT JAVELIN RESERVE PACKING

Use the packing paddle to keep the bridle folds clear and from folding under the Right side flap. **Fig. 38**



Fig. 38

Close the wearer's Right, side flap and pin in place.

NOTE: Be sure to remove the packing paddle once each side flap is pinned in place.

Smooth free bag and bridle as you close each side, filling the outside of the reserve tray.

Work the bulk of material comprising the "ears" to the top outside of reserve container.



Fig. 39

SPORT JAVELIN RESERVE PACKING

After the bulk is spread to the upper outside of the reserve container, push upper tuck flaps under the ears of the free bag with a wooden packing paddle.

NOTE: Be sure that the tuck flaps are not interfering with any other component of the system.



Fig. 40

After side flaps are closed, inspect the skyhook and ensure that the skyhook has remained in place and the red skyhook lanyard and tacking are secure. **Fig. 41**



Fig. 41

**SPORT JAVELIN
RESERVE PACKING**

Once both side upper tuck flaps are stowed, "S" fold the remaining reserve bridle evenly up and down both sides of temporary pin and closing loop, on top of the two side flaps. **Fig. 42**



Fig. 42

Pass the pull up cord up through the pilot chute and out through the grommet in the top plate. This is easily accomplished with a .22 caliber rifle cleaning rod.



Fig. 43

SPORT JAVELIN RESERVE PACKING

Seat the bottom end of the PC on top of the side flaps and bridle over the closing loop.

Prior to compressing the spring, work as much of the F111 material up, between the top plate and first coil of the spring.



Fig. 44

Rotate the F111 towards the main container and compress the spring.

At this point, be sure that binding tape roll offs are positioned at the 12 and 6 o'clock positions. This is so that the top and bottom flap cover these binding roll offs.



Fig. 45

SPORT JAVELIN RESERVE PACKING

Once the spring is compressed and pinned in place, give the P/C material a ½ twist and fan out the p/c fabric, so that it extends wider than the bottom flap. **Fig. 46**



Fig. 46

Be sure to keep the point of the fan or twist, narrow and tight to the middle of the bottom of the p/c top plate and close the bottom flap, Keeping the pilot chute fabric evenly distributed to both sides of the bottom flap. **Fig. 47-48**

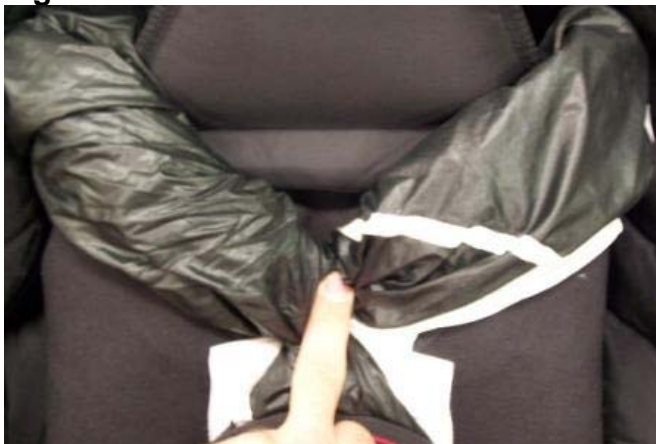

Fig. 47

NOTE: The valley created earlier in the pack job will now become beneficial. This valley will allow for proper seating of the reserve pc spring and fabric.



Fig. 48

**SPORT JAVELIN
RESERVE PACKING**

Pass the end of the reserve pin through the eye on the end of the reserve ripcord cable. **Fig. 49**

Ensure the 45 degree cut is towards the pin.



Fig. 49

Close the reserve pin flap and pin in place with closing pin.

NOTE: Be sure the marine eye on the end of the reserve ripcord cable is **OUTSIDE** of the #0 grommet when complete.

Secure Ripcord Pin lanyard with Velcro slack retainer. **Fig. 50**



Fig. 50

**SPORT JAVELIN
RESERVE PACKING**



Seal rig with one turn Seal thread
and lead seal. **Fig. 51**



Fig. 51

SPORT JAVELIN RESERVE PACKING

Packing WITHOUT the Skyhook.

Place the Free bag into the container.

Make 2 “V” Folds and split so that there is one fold on each side of the closing loop.

Close the skyhook sub flap over the free bag and “V” folds. Pin in place.

Ensure to get as much of the canopy bulk OUT, from under the skyhook sub flap and towards the outboard top corners of the reserve container.

Fig. 52



Fig. 52

First close the wearer’s left, side flap. Use the packing paddle to keep the bridle folds clear and from folding under the left side flap.

Fig. 53



Fig. 53

SPORT JAVELIN RESERVE PACKING

Use the packing paddle to keep the bridle folds clear and from folding under the Right side flap.

Be sure that the running end of the reserve bridle is routed out the top of the reserve container.

Fig. 54

Smooth free bag and material and bridle as you close each side, filling the outside of the reserve tray.

Work the bulk of material comprising the “ears” to the top outside of reserve container.

After the bulk is spread to the upper outside of the reserve container, push upper tuck flaps under the ears of the bag with a wooden packing paddle.

NOTE: Be sure that the tuck tabs are not interfering with any other component of the system.

Once both upper tuck flaps are stowed, “S” fold the remaining bridle evenly up and down both sides of temporary pin and closing loop, on top of the two side flaps.



Fig. 54



Fig. 55

SPORT JAVELIN RESERVE PACKING

Pass the pull up cord up through the pilot chute and out through the grommet in the top plate. This is easily accomplished with a .22 caliber rifle cleaning rod.

Seat the bottom end of the PC on top of the side flaps and bridle, then center on top of the closing loop.

Prior to compressing the spring, work as much of the F111 material up, between the top plate and first coil of the spring.

Rotate the F111 towards the main container and compress the spring. **Fig. 56**

Once the spring is compressed and pinned in place, give the P/C material a ½ twist and fan out the p/c fabric, so that it extends wider than the bottom flap. **Fig. 57**



Fig. 56

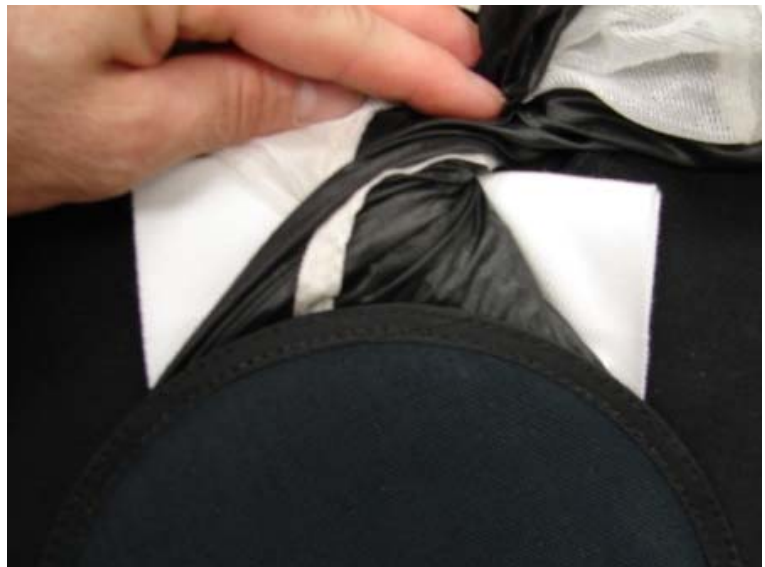

Fig. 57

SPORT JAVELIN RESERVE PACKING

Be sure to keep the point of the fan or twist, narrow and tight to the middle of the bottom of the p/c top plate and close the bottom flap, keeping the pilot chute fabric evenly distributed to both sides of the bottom flap.

Close the reserve bottom flap and pin in place. **Fig. 58**

After bottom flap is seated, carefully place the PC fabric under the flap. Ensure that the PC fabric is on top of the bridle folds.



Fig. 58

NOTE: The valley created earlier in the pack job will now become beneficial. This valley will allow for proper seating of the reserve pc spring and fabric.

Pass the end of the reserve pin through the eye on the end of the reserve ripcord cable as shown. **Fig. 59**

Ensure the 45 degree cut is towards the pin.



Fig. 59

SPORT JAVELIN RESERVE PACKING

Close the reserve top flap and pin in place with the closing pin. Ensure that the end of the pin is under the Type 3 tape protective sleeve on the pin flap.

Fig. 60

NOTE: Be sure the marine eye on the end of the reserve ripcord cable is **OUTSIDE** of the #0 grommet when complete.



Fig. 60

Secure Ripcord Pin lanyard with Velcro slack retainer.

Fig. 61



Fig. 61

**SPORT JAVELIN
RESERVE PACKING**

Seal rig with one turn Seal
thread and lead seal as shown
here. **Fig. 62**



Fig. 62

THE 3-RING RELEASE CABLE LENGTHS

After the cables have been installed in the housings of your **JAVELIN/JAVELIN ODYSSEY** there should be 140mm (5.5") on the wearer's left hand side (non RSL side) and 153mm (6") on the wearer's right side. (RSL side) These measurements are based on extensive testing and should not be altered in any way to change the correct operation of the RSL/Collins lanyard.

THE 3-RING RELEASE SYSTEM

The 3-Ring Release system was invented by the Relative Workshop in 1976. It was the first practical release that allowed parachutists to jettison their main canopies in one motion by simply pulling a single handle. Not only is the 3-Ring easier to operate than previous canopy release systems, it is also more reliable. Failures of a properly built and assembled 3-Ring system are virtually unknown. Once the main is jettisoned, the only things left on the harness are the two smooth rings that cannot snag a deploying reserve. Some other popular release systems can and have interfered with the deploying reserve.

GETTING TO KNOW THE 3-RING

Knowing how the 3 ring release works will help you assemble and inspect it properly. Begin by peeling the release handle from the Velcro on the harness. Peeling, rather than pulling, makes it easier to separate the handle from the webbing. Look behind the risers near the harness and observe the movement of the yellow cable as you pull the handle. When the cable clears the white loop, the release is disengaged. Now slowly pull one of the risers off the harness. As you pull, you'll notice that the white loop gets pulled through the grommet by the action of the smallest ring. Each ring forms a lever with a ten-to-one mechanical advantage as it passes through the other. A force of 1,000 lbs on the large harness ring exerts a force of only ten pounds on the white loop. (Opening shock usually totals about 1,000 lbs or 500lbs on each riser).

NOTE:
**SUN PATH DOES NOT RECOMMEND THE USE OF
REVERSE RISERS ON JAVELIN/JAVELIN ODYSSEY
HARNESSES/CONTAINER SYSTEMS.**

Because of the mechanical advantage provided by the 3-Ring design, only a force of approximately a pound on the top ring keeps the release together. That's why it's important to keep foreign matter like bits of grass and sticks out of the 3-Ring assembly. A small stick in the white loop could prevent a riser from releasing. It is also important to understand one of the properties of the nylon components of the system. When nylon stays in the same position for a long time, it begins to conform to that position, or take a "set". If the 3-Ring release system stays assembled for too long, the nylon can become so stiff that the low drag from a malfunction (such as a streamer) won't pull the riser off the ring. The 3-Ring release system must be disassembled, flexed and inspected every month. Procedures for this are listed in the maintenance chapter of the manual.

ASSEMBLY

Before assembling the 3-Ring release, make sure the risers aren't twisted or reversed. Lay the JAVELIN face down, as you would to pack it.

1. Thread the cable into its housing and stick the cut away/release handle to the harness. The handle should be positioned as close to the ends of the housings as possible so that no cable is exposed.

2. With the rings of the riser facing toward the floor, pass the ring on the end of the riser through the large harness ring from above. Fold it back toward the canopy and risers (**FIG 1**).

3. Thread the smallest ring through the middle ring in the same way, but make sure it doesn't pass through the large ring (**FIG. 2**).

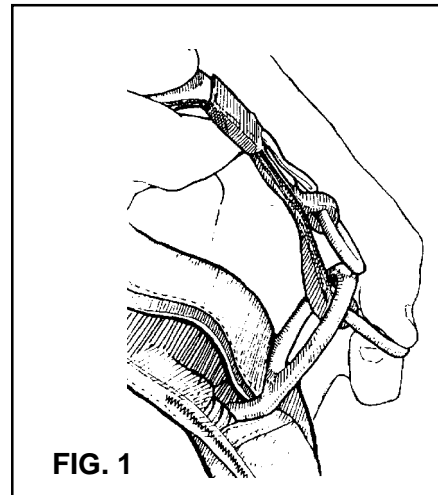

FIG. 1

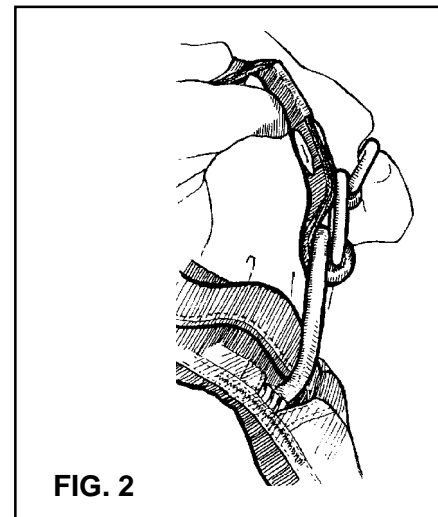
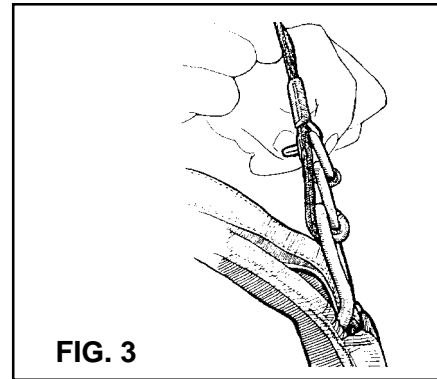

FIG. 2



4. Bring the white loop over the small ring only and then through the riser grommet so it pokes out the back of the riser (**FIG 3**).



5. Continue threading the white loop through the grommet on the end of the cable housing. The flat side of the cable housing grommet should be against the riser (**FIG 4**).

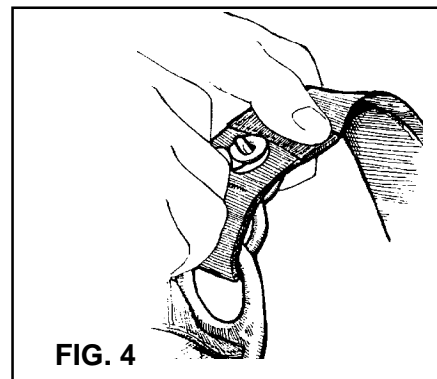

6. Thread the yellow cable through the white loop, making sure the loop isn't twisted (**FIG 5**).

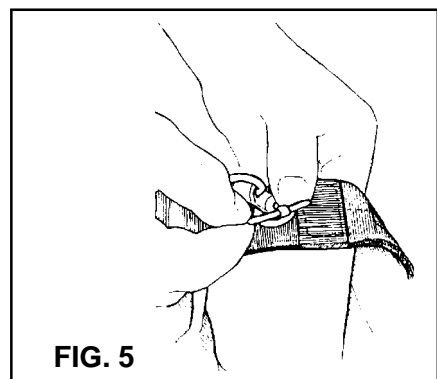

7. Be careful with the cable so you don't bend it too sharply or kink it (**FIG 6**).

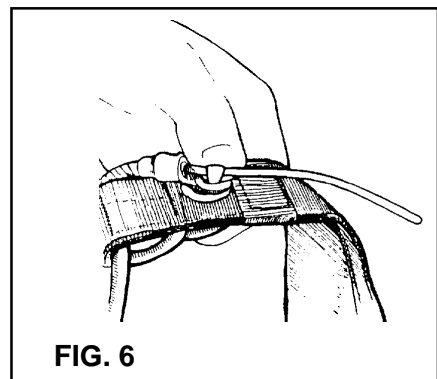

8. Insert the free end in the channel on the back of the riser (**FIG. 7**).
Repeat the above steps with the other riser.

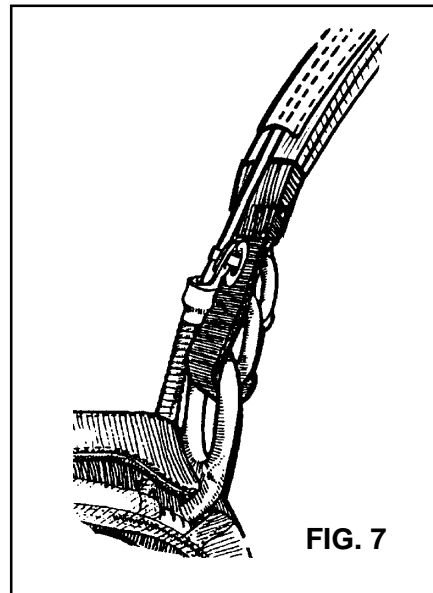

REQUIRED PERIODIC MAINTENANCE FOR THE 3-RING

The Booth 3-Ring Release System has been in use for many years with excellent results. Although the system is as durable as the rest of the harness/container assembly, it requires periodic maintenance and inspection to ensure proper operation. Generally it is NOT recommended that the risers be attached to the harness when new and "forgotten." Like all skydiving gear, the 3-Ring Release should be carefully inspected and operated on a regular basis. The procedures below should be done at least every month. This is especially important if the rig has not been used for a month or more, such as during the winter. Immediate inspection is required if it has been subjected to some abuse such as a drag across the runway, a water landing or exposure to a lot of dust or sand.

1. Every month operate the 3-Ring release system on the ground. Extract the cable completely from the housings and disconnect the risers.
2. While the system is disassembled, closely inspect it for wear. Check the white locking loops (the ones that pass over the smallest ring and through the grommet) to be sure they are not frayed.
3. Check the Velcro on the breakaway handle and main lift web to be sure it is clean and adequately holds the handle.
4. Check the cable ends for a smooth finish. The ends are finished at the factory to have a smooth, tapered surface. This prevents the cable from hanging up in the loop. Check the cable ends and consult a rigger or the manufacturer if a burr or "hook" is present.
5. Check the stitching, including that which holds the large rings to the harness.
6. Pull downward on the housings. They shouldn't move downwards more than 1/2 inch.



7. Take each riser and vigorously twist and flex the webbing near where it passes through each ring. The idea is to remove any set or deformation of the webbing. Do the same thing to the white loop. **(FIG. 1)**
8. Check the housings for dents or other obstructions. Use the cable to do this.
9. Clean and lubricate the release cable with a light oil such as a "3-in-1" brand. Put a few drops on a paper towel and firmly wipe the cable a few times. A thin, invisible film should remain--too much will attract grit and dirt, or the oil could become tacky in cold weather. Too much oil will require more force to extract the cable during a breakaway.
10. Inspect the fittings at the end of each housing. If one of these fittings were to come off the housing, a riser might release prematurely.
11. If any wear is found, consult a rigger or the manufacturer before using the JAVELIN.
12. Reassemble the system. Double check it. Make sure the risers aren't reversed. It's important to maintain the system even more frequently in humid, muddy or freezing conditions. If the JAVELIN becomes immersed in mud or muddy water, clean the 3-Ring release system with a mild solution of soap and water. Any rusted components must be replaced.

BEFORE USING THE JAVELIN

1. Read and understand this manual and be qualified by proper instruction for sport parachuting activities.
2. Check both 3-Ring releases to see that they are correctly assembled and check to see the release handle is securely attached (Velcro) to the main lift web.
3. Check the main container closure for correct pin position and correct routing of the bridle. The little velcro tab on the bridle must be mated to the one on the top flap.
4. Check the reserve container for correct pin closure and routing of the ripcord. Be sure the reserve ripcord handle is well seated in its velcro pocket.
5. The main pilot chute must be protected by its pouch, but the handle must be easily accessible and or visible.

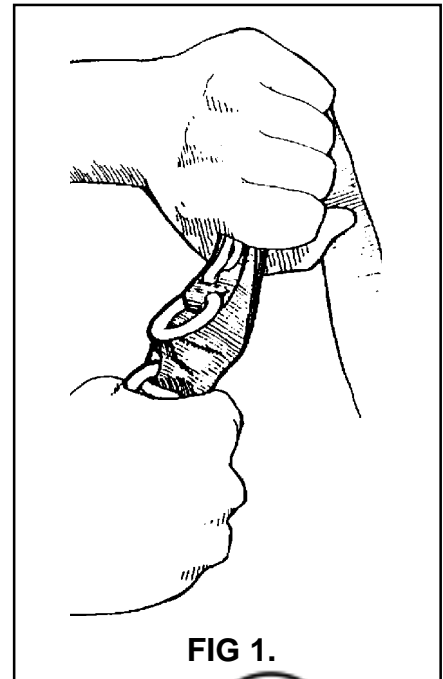

FIG 1.



DONNING THE JAVELIN

When lifting the JAVELIN, grasp the main lift web between the large harness ring and the chest strap. Put the rig on as you would a jacket, settling the yoke across the shoulders. Step through the leg straps, **being sure they aren't twisted**, then thread the chest strap through its friction adapter (adjustor) and tighten it to where it is comfortably snug. Be sure it has NOT been threaded through the reserve ripcord handle.

Tighten the leg straps until they are comfortably snug and stick the free end of the strap down into the leg pad or in an elastic keeper. It is important to secure these free ends; a loose free end can easily be mistaken for a deployment handle.

RING HARNESS ADJUSTMENT

If your Javelin is equipped with a ringed harness, to insure a proper and comfortable fit, it is very important that you tighten the chest strap first. By first tightening the chest strap very snugly, this will allow full arm and shoulder movement. Next tighten the leg straps until they are comfortably snug. (FIG. 1)

Be sure all the friction adapters are correctly threaded. The webbing must pass under the adapter (next to the jumper's body) and come up through the frame above the moveable bar, then back around the moveable bar and under the end of the frame. If the webbing is routed in any way other than what is shown in

(FIG. 2) or (FIG. 3). **IT MAY NOT HOLD!**

(1" chest strap) Fold the free end of the chest strap back onto the short side and stow the excess in the 1" elastic keeper (FIG. 4).

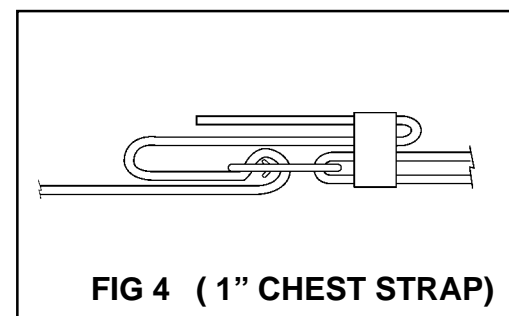
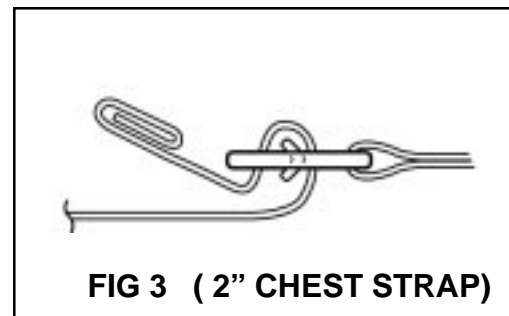
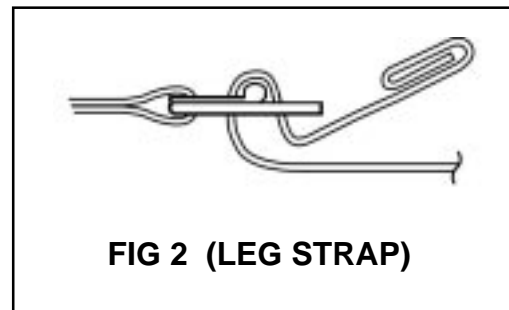
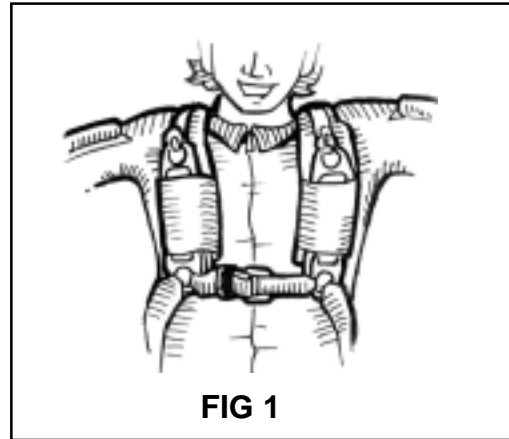

This section is not a full course of instruction on how to deal with emergencies. It is meant only to explain the function of the JAVELIN harness/container system. Learning the proper procedures and deciding when, or if, to use them is the responsibility of the jumper, who must be thoroughly trained by an experienced and qualified instructor before attempting to make a parachute jump.

MAIN DEPLOYMENT

BEFORE JUMPING

The pouch for the main pilot chute is located at the right hip on the outside of the right leg pad or on the bottom of the main container. When the pilot chute is packed correctly, the handle should be visible and easy to grasp at the top of the pouch. (It is very important that the jumper familiarize himself with all handles and activation devices on his rig before jumping). Practice locating the handle, grasping it and extracting the pilot chute. Then go through the same procedure without looking at it. This should be done under the supervision of an instructor. The pilot chute pouch location on some JAVELIN's will not allow the handle to be visible. i.e. JAVELIN's fitted with B.O.C. (Bottom of Container) or pull out.

IN THE AIR

In a flat and stable position face-to-earth, grab the pilot chute handle and in one motion, extract the pilot chute from the pouch and vigorously throw it STRAIGHT OUT to the side, placing it in clean air. If you are in the air with other jumpers, the wave-off should be done before extracting the pilot chute. Waving off with the pilot chute in hand may cause a premature opening of the container.

RESERVE DEPLOYMENT

PARTIAL MALFUNCTION

A partial malfunction occurs when the canopy has come out of the container, but has not opened properly. Most jumpers are now trained to jettison (disconnect) the main canopy before activating the reserve if the partial malfunction is serious enough to warrant emergency procedures. Disconnecting from the main is called a "breakaway" or "cutaway" and it is done to prevent the entanglement of the reserve with the main.

PROCEDURE

Look down and locate both the cutaway/release handle (on right main lift web) and the reserve ripcord handle (on left main lift web). Grab the cutaway/release handle and peel it away from its velcro mount. Pull it vigorously downward and outward as far as the arm will reach. Throw it away and then grasp the reserve ripcord handle. Pull it vigorously downward and outward as far as the arm will reach. It must be emphasized that it is the jumper's responsibility to decide whether any emergency procedure is appropriate and to decide whether he has enough time or altitude to perform it. Obviously if the jumper decides that he is too low to perform a breakaway, he should simply activate the reserve.



TOTAL MALFUNCTION

A total malfunction occurs when the main canopy is still in the container after an attempt has been made to activate it. This may occur if the pilot chute cannot be extracted from its pouch, or if the pilot chute is inflated but cannot open the container. It is generally considered best when presented with a total malfunction to simply pull the reserve ripcord without breaking away from the main canopy. A total malfunction always leaves the jumper falling at high speed and breaking away from a canopy that is still in the container may waste precious time and altitude.

PROCEDURE

Look at the reserve ripcord handle (the metal handle or soft handle just below the chest strap on the left main lift web), grasp it with both hands and pull it downward and outward with all your strength and as far as you can reach. It is usually considered best to be in a stable position somewhat head-high when deploying any canopy, but if time and altitude are running out, body position is not as important as getting the canopy out!

DEAR JAVELIN OWNER,

It is the goal of SUN PATH PRODUCTS, INCORPORATED to produce and sell the best sport parachute equipment that can be manufactured with today's materials and technology. In this effort, it is important that we obtain all the feedback from our customers that we can. We would like for you to share with us any observations, problems, suggestions, etc., that you may have. Our primary concern is of course the SAFETY and DEPENDABILITY of the JAVELIN harness/container system. After that, ***your satisfaction comes first.***

We thank you for your choice of the JAVELIN and we hope for your continued confidence in SUN PATH PRODUCTS INC.

BLUE SKIES and SAFE DIVES,
SUN PATH PRODUCTS, INC.



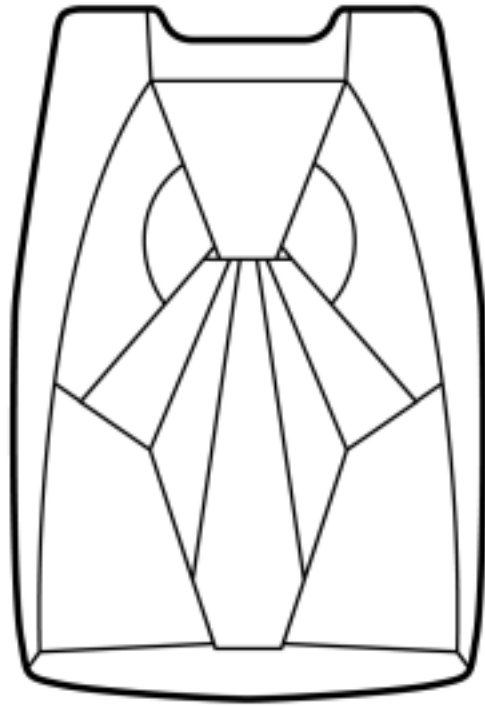
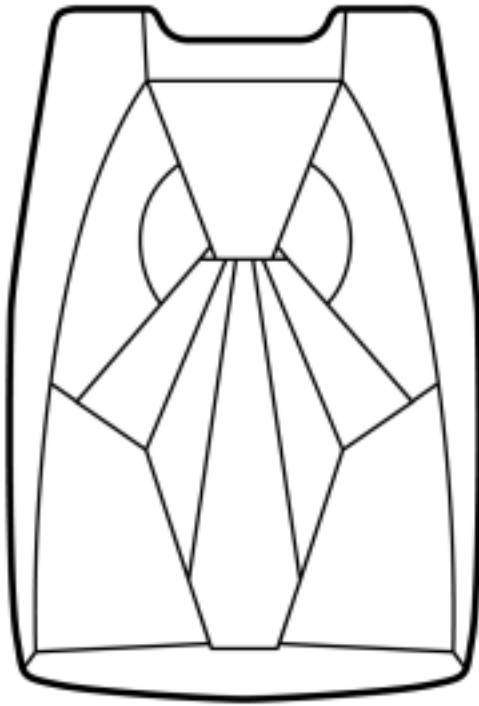

Copy and color
this page is to help you
pick the colors for your
next **JAVELIN**.

Check out the
on-line color selector at:
www.sunpath.com

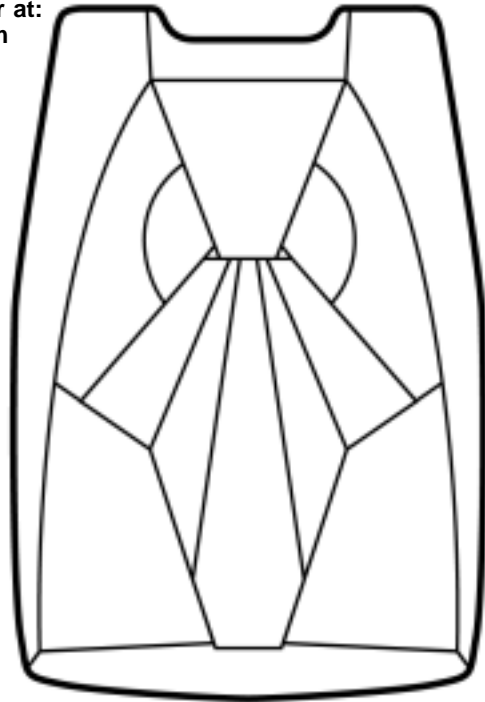
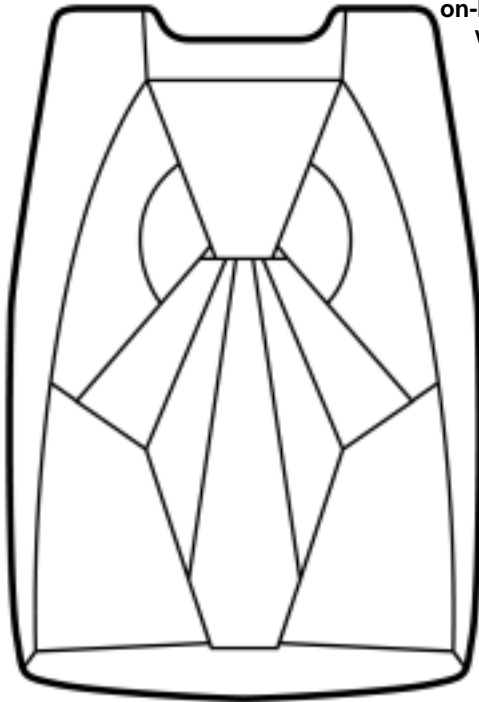

4439 Skydive Lane Zephyrhills, FL 33540 USA
Phone (813) 782-9242 Fax (813) 788-3057

www.sunpath.com

Appendix A: Maintenance and Repairs

Applicable to all Javelin and Javelin Odyssey harness/container systems, sport and student.

Your Javelin/Javelin Odyssey harness container system is built with the latest technology and most up to date manufacturing methods.

QUALIFIED PERSONNEL:

It is strongly recommended that all major repairs to Javelin/Javelin Odyssey harnesses and container systems be made at the manufacturers' facility in Zephyrhills, Florida.

AUTHORIZATION:

Javelin/Javelin Odyssey harness/container systems are certified under TSO c23d. The TSO label is located under the reserve pin cover flap, behind the warning lable on the back pad or inside the pocket on the yoke if the rig has a clear reserve pin cover. If this label is not present or has been removed **DO NOT PACK THE RIG.** **Removal of the TSO label voids the TSO and all certification approvals.**

IF THERE ARE ANY VISIBLE SIGNS OF WEAR OR DAMAGE, HAVE YOUR RIG THOROUGHLY INSPECTED BY A CERTIFIED PARACHUTE RIGGER OR OUR MANUFACTURING FACILITY IN ZEPHYRHILLS, FLORIDA BEFORE NEXT USE.

LIMITS AND GUIDELINES FOR DAMAGE:

Limits and guidelines for webbing are applicable to all sections of the harness. To include reserve risers, main lift web, lateral/diagonal and leg straps.

At every repack cycle, the entire harness/container system should be thoroughly inspected. Completion of this inspection and annotation of an A/I/P or A/I/R on the packing data card implies that the certifying party has inspected and deemed the harness, container and all applicable components to be airworthy and ready for use.

A visual inspection of the harness webbing and hardware should be conducted before each use to determine whether or not it is showing signs of abrasion, fraying, nicks, unusual wear and tear or any other visible damage to any part of the webbing and or hardware damage that will degrade its strength. Refer to the following grading list as a guideline for determining webbing wear.

■ **Grade 1** Like new, does not need replacement. See Fig. 1

■ **Grade 2** Minor Hook and Loop type abrasion.
Minor wear due to normal use. Replacement optional, make note to inspect specific area on every repack cycle. See Fig. 2

■ **Grade 3** Any damage to selvedge edges of harness webbing. Broken or missing harness stitching. Mandatory replacement or repair. See Fig. 3

Figure 1 **Grade 1**

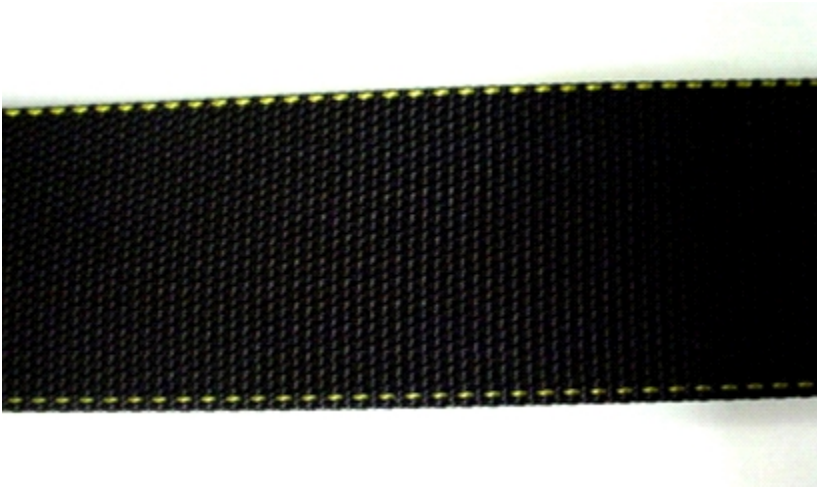
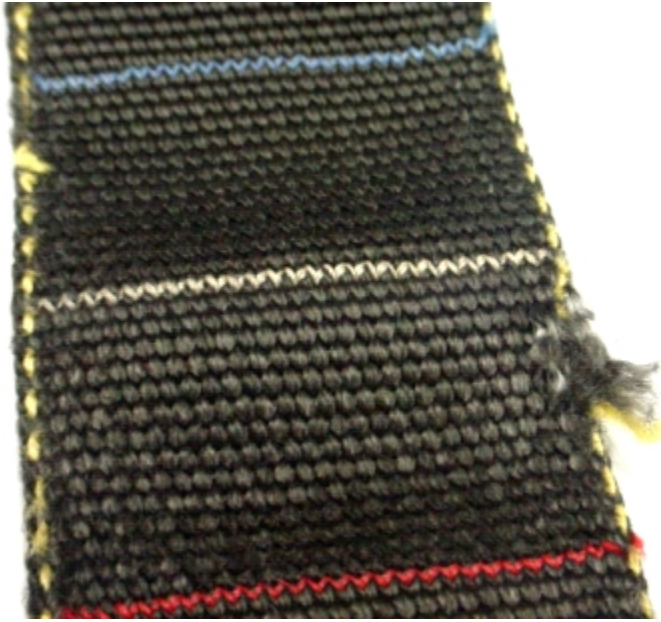

Figure 2 **Grade 2**



Figure 3 Grade 3



STORAGE:

Textiles and other materials used in the manufacture of parachute equipment to include harness/container systems are sensitive to the following environmental elements.

- Water/humidity
- Salt water
- Ultraviolet rays (Sunlight)
- All petroleum based products (oil, grease)
- Rodents, pests
- Smoke
- Excessive heat
- Chlorine (bleach)
- Acid

While the parachute equipment is not in use it is recommended to store the gear in a proper gear bag and in a room where the temperature and humidity is maintained.